

90 / 120 / 180 / 240 SHX / SVX BLOWER COIL UNITS

INSTALLATION, OPERATION & MAINTENANCE INSTRUCTIONS

******* WARNING TO INSTALLER, SERVICE PERSONNEL AND OWNER *******

Altering the product or replacing parts with non authorized factory parts voids all warranty or implied warranty and may result in adverse operational performance and/or a possible hazardous safety condition to service personnel and occupants. Company employees and/or contractors are not authorized to waive this warning.

GENERAL

The manufacturer assumes no responsibility for equipment installed in violation of any code requirement.

These instructions give information relative to the installation of these blower coil units only. For other related equipment refer to the proper instructions.

Material in this shipment has been inspected at the factory and released to the transportation agency in good condition. When received, a visual inspection of all cartons should be made immediately. Any evidence of rough handling or apparent damage should be noted on the delivery receipt and the material inspected in the presence of the carrier's representative. If damage is found, a claim should be filed against the carrier immediately.

******* WARNING *******

Unit must not be operated during building construction due to excessive airborne dust and debris. The units must not be operated under any circumstances without an air filter in place.

BLOWER COIL UNIT

The installer must adhere strictly to all local and national code requirements pertaining to the installation of this equipment.

The SHX blower coil units are designed to be installed in a horizontal position with discharge air in a horizontal direction. The SVX blower coil units are designed for installation in a vertical position with discharge air in a vertical direction. Both unit models incorporate a positive slope drain pan with a 3/4" NPT nipple that exits the unit on the side of the coil header connections. All units need to be leveled in such a way to insure positive slope toward the condensate drain nipple.

NOTICE: Before mounting unit remove red headed shipping bolts and metal bushing at blower base and blower outlet. In addition remove, if present, the wire tie securing motor to blower rail before operating.

Sufficient clearance must be provided on the side of the blower coil to allow access to electrical controls and to service the motor blower assembly.

Standard unit configuration is right hand looking with the direction of airflow. The unit can be field converted to left hand by repositioning the coil, drain pan and remounting the motor and pulleys.

NOTE: Motor rotation must be reversed. See motor nameplate for details.

AIR DISTRIBUTION DUCTS

All duct work must be installed in accordance with National Fire Pro-

tection Association Codes 90A and 90B. Ducts should be adequately insulated to prevent condensation during the cooling cycle and to minimize heat loss during the heating cycle. All return air must be filtered to prevent dirt buildup on the coil surface. In many cases it is acceptable to use ducting of the same size as the blower coil return air connection. However, unique arrangements or long duct runs must be confirmed by a local professional. The manufacturer will not be responsible for misapplied equipment.

ELECTRICAL

All wiring must comply with local and national code requirements. Units are provided with wiring diagrams and nameplate data to provide information required for necessary field wiring. A 4 x 4 electrical box is provided on the cabinet for connection of power supply.

******* WARNING *******

Any devices such as fan switches or thermostats that have been furnished by the factory for field installation must be wired in strict accordance with the wiring diagram that is supplied with the unit. Failure to do so could result in damage to components and will void all warranties.

PIPING

These units are supplied with a direct expansion refrigerant coil. The standard refrigerant metering device is a thermostatic expansion valve. The suction and liquid lines must be sized in accordance with the outdoor unit manufacturer's recommendations and require sweat connections at the blower coil unit. Piping must be installed in accordance with all applicable codes.

******* WARNING *******

When connecting piping to blower coil units, do not bend or reposition the coil header tubing for alignment purposes. This could cause a tubing fracture resulting in a refrigerant leak when the system is charged.

Caution: Prior to connecting to the blower coil all external piping must be purged of debris.

Condensate drain lines must be installed with adequate slope away from the unit to assure positive drainage. Since the drain pan is located on the suction side of the blower, a negative pressure exists at the drain pan and a minimum trap of 2 inches must be provided in the drain line to assure proper drainage.

NOTE: Drain pan has positive slope to the nipple which is located on the coil connection side of the unit.

GENERAL PIPING PRECAUTIONS

1. Flush all field piping prior to connection to remove all debris. Recommend dry nitrogen.
2. Use wet cotton rags to cool valve body when brazing.
3. Avoid rapid quenching of brazed joints as this will produce joints of inferior quality.
4. The coil suction and liquid fittings will not support the weight of the connecting pipes. All pipes which are connected to the unit must be completely supported prior to connection to the unit.
5. All piping fabricated in the field should be installed with consideration of additional space for any

electrical routing or servicing that may be required.

6. Connect all piping per accepted industry standards and observe all regulations governing installation of piping systems. When all connections are complete the system must be pressure tested. Repair any brazed joint leaks.

PIPING INSULATION

After the system has been proven leak free, all suction lines must be insulated to prevent condensate drippage or insulated as specified on the building plans.

DUCT WORK

All duct work must be installed in accordance with industry accepted practices, and all applicable national and local code requirements.

NOISE

These blower coil units are designed for quiet operation, however, all air handling equipment will transfer some amount of noise to the conditioned space. This should be taken into consideration when planning the location of the equipment.

MOUNTING

It is important to ensure that the blower coil unit is securely mounted and the structure is sufficient to support the weight of the equipment. The SHX blower coil units are intended to be mounted with a support angle or channel located under the unit. There are 7/8" knockouts located at all four corners top and bottom which permits field supplied hanging rods to extend through the unit to secure to the field supplied angle or channel. (See figure 1) All anchors for mounting the equipment must be placed and sized to ensure a safe and durable installation. When necessary use shims to obtain the proper level. This will ensure that the condensate will drain from the unit.

INSTALLATION PRECAUTIONS

Installation of this equipment should only be performed by qualified personnel to ensure proper installation and the safety of the installer. The following are some precautions to be followed for typical installations.

1. Always use proper tools and equipment.
2. No wiring or other work should be attempted without first ensuring that the blower coil is completely disconnected from the power source and locked out. Always verify that a good ground connection exists prior to energizing any power sources.
3. Always review the nameplate on each unit for proper voltage and control configurations. This information is determined from the components and wiring of the unit and may vary from unit to unit.
4. When soldering or brazing to the unit it is recommended to have a fire extinguisher readily available. When brazing close to an expansion valve or other components heat shields or wet rags are required to prevent damage.
5. When the blower coil unit is in operation components are rotating at high speeds.
6. Units must be installed level to ensure proper drainage and operation.
7. Check unit prior to operation to ensure that the condensate water will drain toward the drain connection. An auxiliary overflow pan may be required as a back up to a clogged primary drain.
8. Be sure that the drain pan is free from foreign material prior to start up.
9. Check filter media installation to ensure that it is installed correctly. Use the directional arrows or other information on the filter to determine the proper flow direction.
10. Ensure that the air distribution system does not exceed the external static rating of the unit. This could cause the motor to activate its internal motor temperature protector and shut off on safety.

START-UP OPERATION

Pre-start Check

1. Check that supply voltage matches nameplate data.
2. Ensure that the unit is properly grounded.
3. With power off, ensure that the blower wheel(s) rotate freely and quietly.
4. Verify that the lines were properly cleared of debris prior to sealing.
5. Check that coil(s), expansion valve(s) and piping have been leak

SHW MODELS

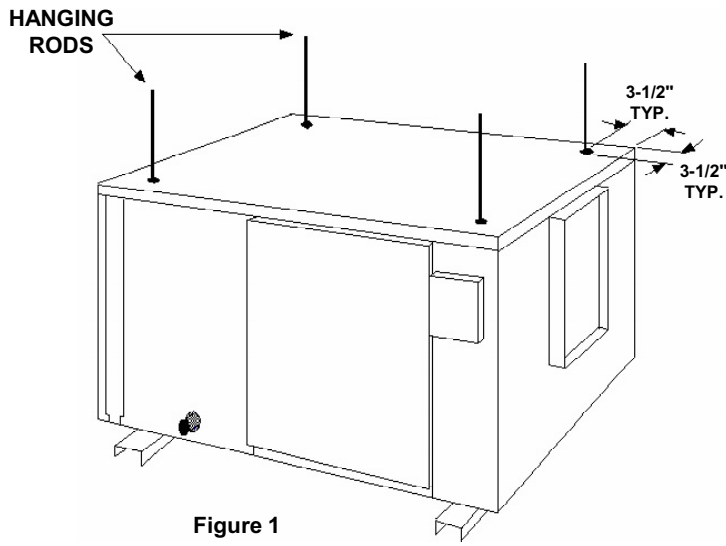

Figure 1

checked and insulated as required.
 6. Install all panels.
 7. Install any filters which may have been removed during the installation process.

******* WARNING *******
If an auxiliary hot water coil is installed in the unit then a freeze protecting thermostat or similar device is recommended to prevent the freezing of the water coil if an abnormal evaporator condition occurs.

Blower Speed Adjustment

Adjustment of blower speed is made by loosening the set screw in the outer (movable) pulley face and turning this face half or full turns only, so that the adjusting set screw will be positioned precisely over the flat on the pulley hub. Speed is reduced by adjusting the pulley faces so that they are further apart; speed is increased with faces closer together. Check all of the pulleys' set screws for tightness.

Inspection and Cleaning

Before start-up all of the components should be given a thorough

check. Optimal operation of this equipment requires cleanliness. Often after installation of this equipment additional construction activities occur. Care must be taken to protect the equipment from debris during these construction phases.

******* WARNING *******
The manufacturer does NOT WARRANT equipment subjected to abuse. Metal chips, dust, drywall tape, paint over spray, etc. can void warranties and liability for equipment failure, personal injury and property damage.

MAINTENANCE

To achieve maximum performance and service life of each piece of equipment a formal schedule of regular maintenance should be established and maintained by a certified contractor.

The following is provided as a recommended maintenance schedule. Specific instructions for maintenance procedures are given after the check list.

Monthly Check List

- Inspect the unit air filters. Clean or replace as required.
- Inspect the drainpan to be sure it is

******* WARNING *******

- Always wear eye protection.
- When blower coil is operating, some components are operating at high speeds. Personal injury can result from touching these items with any object
- All electrical and service access panels must be returned and secured in their proper place.
- Clear surrounding area of all tools, equipment and debris.
- Check the entire unit to ensure it's cleanliness.

clean to permit the flow of condensate through the drain lines.

- Inspect the fan belt for wear and alignment. Replace or adjust as required.

Yearly Check List

- Clean the blower motor and oil if required.
- Inspect the blower coil unit casing for corrosion and loose fasteners.
- Inspect the blower wheel and housing. Clean if necessary.
- Check the motor pulley and blower pulley for alignment and tighten their set screws. Adjust belt tension if necessary.
- Inspect all coil connections for leaks. Inspect the coil fins for excessive dirt or damage. Clean or repair if required.

******* WARNING *******

Disconnect electrical power and allow all rotating equipment to stop before servicing the unit. Failure to do so may result in personal injury or death from electrical shock or entanglement in moving parts. Note: Multiple circuits may be involved so verify with a meter or suitable voltage indicating device.

Blower

Inspect the bearings for wear. They are ball bearing, self-aligning and grease packed. Replace if required. Inspect the thrust collars for end play and alignment of wheel. Check the

blades for accumulations of dirt and clean in order to avoid imbalance and vibration. Check mounting brackets, base bolts and isolation material.

Motor

Check motor connections to ensure that they are secure and made in accordance with the wiring diagram.

The blower motor should be cleaned annually and if it has oiling ports, it should be oiled with a good grade of SAE 20 oil. Normally a few drops of oil in each bearing is sufficient.

Pulley Alignment and Belt Tension

Belt tension and pulley alignment should be checked. Belt tension is adjusted by means of the motor tail-piece adjusting bolt or the position of the motor on the base style motor mount. A deflection of about 3/4" to 1" per foot of span should be obtained by pressing the belt firmly. The adjusting bolt should be locked in position after the adjustment is made. Alignment of pulley grooves is made by locating the motor pulley on the motor shaft or by moving the entire motor along the motor mounting bracket. For blower speed adjustment refer to that section.

Coil

Any dust or other contaminants which accumulate on the heat transfer surfaces interferes with the air flow and impairs heat transfer. The coil must be kept clean by any of the following methods.

1. Cleaning with low pressure compressed air.

2. Flushing or rinsing with water (a detergent is advisable for greasy surfaces).

Filter

The air filter should be cleaned or replaced as often as necessary to prevent restriction of air flow. Always replace the filter with the same type as originally furnished.

To clean permanent filters, remove the filter and wash in water to remove the old filter oil. Rinse in clean, hot water and allow to dry. Recoat both sides of the filter with RP filter coat, or an equivalent. Allow to drain and dry thoroughly before reinstalling the filter.

Drain Piping

The drain should always be connected or piped to an acceptable disposal point sloped away from the unit. Check the drain line for restrictions or blockage before summer operation and monthly during the cooling season.

Drain Pan

The drain pan should be clean to allow proper condensate flow. Remove any accumulation of residue from the drain pan and inspect for rust and leaks.

