



Heating and Cooling

Product Specifications

**HBC50 Series
PHBC50 Series
RHBC50 Series
CHBC50 Series**

**Hydronic Fan Coils
300-1400 cfm**

220V, 50Hz Models for Export

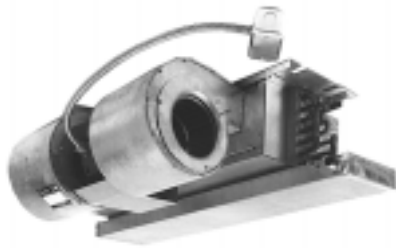

HBC50 Series
(furred-in ceiling model)

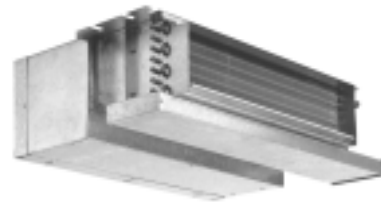

PHBC50 Series
(furred-in ceiling model
with return plenum)



RHBC50 Series
(recessed cabinet model with
telescoping access panel)



CHBC50 Series
(cabinet exposed)

Table of contents

DESCRIPTION	PAGE
General Construction Features	4
Standard Features	4
Model Number Nomenclature	4
HBC50 Series - Physical Data and Submittal	5
PHBC50 Series - Physical Data and Submittal	6
RHBC50 Series - Physical Data and Submittal	7
CHBC50 Series - Physical Data and Submittal	8
3-Row Performance Data	9
4-Row Performance Data	10
Split Coil (4-Pipe) Heating Data	11
Cooling Correction Factors	12
Valve Clusters and Individual Components	13
Ceiling Access Panels	14
Guide Specifications	14

Note: See Bulletin Number HBCBP50 for blower performance tables

HBC50 Series - hideaway ceiling model

The HBC50 Series hideaway unit is designed for fully concealed installation in a furred-down ceiling space. This is an open blower type fan coil requiring a sealed return air space. Filter, return plenum, and access panel are not provided with the base unit.

The space-saving HBC50 is only 10" high and is designed to provide easy access for service and maintenance of the entire assembly.

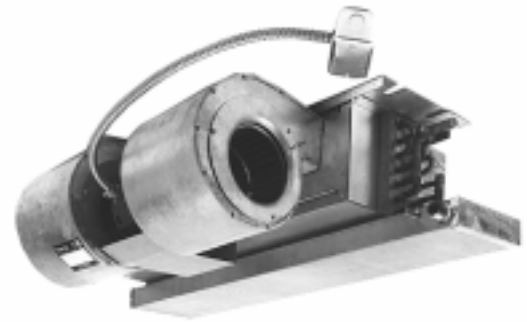

PHBC50 Series - hideaway model with plenum

This unit consists of an HBC50 Series fan coil with factory installed return air plenum. Return air ducting can be easily attached to the unit plenum. The plenum is also field-convertible from end to bottom return air.

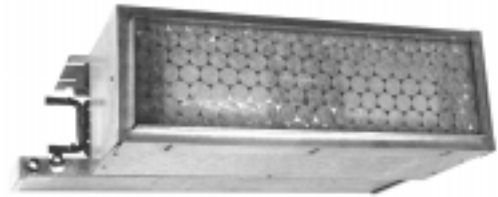

RHBC50 Series - recessed ceiling model

The RHBC50 Series fan coil with hinged ceiling panel is designed for recessed ceiling applications.

The unit consists of an HBC50 fan coil totally enclosed in a cabinet with decorator style hinged access panel that also serves as a return air panel.

The ceiling frame and access panel are adjustable to permit easy field adaptation to most ceiling types for custom fit and maximum accessibility to the unit and controls. The cabinet is notched to allow for a ducted rear return and a solid bottom access panel is also available.



CHBC50 Series - exposed ceiling model

The CHBC50 Series fan coil is designed for installations where sufficient room for ductwork isn't available. It contains all of the features of the HBC50 Series and includes a decorative cabinet with stamped discharge grille. The cabinet has an attractive baked on off white enamel finish. An attractive stamped return air grille in the hinged bottom panel is standard.



First Co.'s hydronic fan coil line begins with the ever popular HBC50 series which First Co. has been manufacturing for many years. A return plenum can be installed on the HBC50 (PHBC50) or the HBC50 can be factory installed within one of two cabinets for either exposed ceiling mounting (CHBC50) or recessed ceiling mounting with telescoping access panel (RHBC50). See pages 8 through 11 for performance data and dimensions.

For blower performance tables see Bulletin Number HBCBP50

General Construction

Basic Unit

All fan coils are manufactured with heavy gauge galvanized steel to resist corrosion.

Piping, drain, and wiring connections are readily accessible and mounting holes and/or slots are pre-drilled to save installation time and field labor expense.

Plenums and Cabinets

Plenums and cabinets are insulated to increase efficiency and to insure quiet operation. Exposed cabinets and access panels are coated with an attractive baked on finish. All models (except HBC50 Series) have throwaway filters. Hinged panels are included with the RHBC50 and CHBC50 models for easy access and service.

Motors

Standard motors are 220V, 50Hz, 3 speed, PSC type with internal thermal overload protection and are mounted with rubber bushings. Blower wheels are centrifugal, forward curved, and dynamically balanced.

Coils

Coils have 3/8" O.D. copper tubing expanded to high efficiency aluminum fins. Each coil is factory tested to 350 psig. Manual air vents are standard on all coils. Tube connections are 5/8" O.D. Left and right hand coil connections are available (looking with airflow, from the blower end). We furnish right hand, if hands are not specified on the order.

Drain Pans

All drain pans shall be coated on the inside surface with a closed cell, fire retardant foam insulation. This insulation provides superior corrosion resistance. All drain pans include both primary and secondary (overflow) drain connections. All drain pans are sloped toward the drain connections to facilitate condensate removal.

Standard Features

HBC50 / PHBC50 / RHBC50 / CHBC50

These fan coils are completely factory assembled and are available in either 2 pipe or 4 pipe arrangements. Models are available with 300 to 1400 cfm, cooling capacities up to 40,000 BTUH, and heating capacities up to 110,000 BTUH. Two pipe models are available in 3 and 4 row versions and four pipe models are available in 3 or 4 row cooling and 1 or 2 row heating versions.

Options (1)

Available options include motorized/hand valve packages, thermostats, aquastats, extended drip pans, 3-speed switches, and ceiling access panels for the HBC50/PHBC50 models. Contact factory for other available options.

Model Number Nomenclature

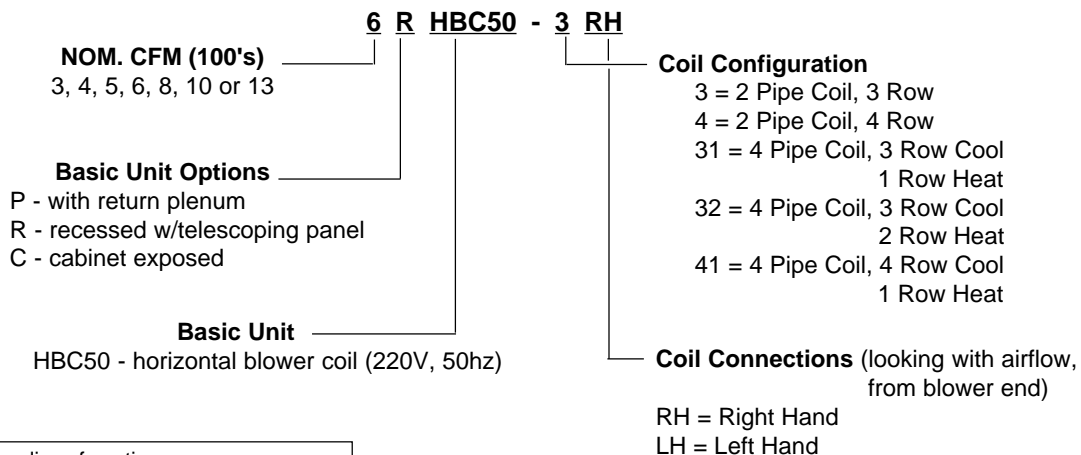

"In keeping with its policy of continuous progress and product improvement, First Co. reserves the right to make changes without notice."

NOTES:

- 1) ALL DIMENSIONS IN INCHES.
- 2) COIL CONNECTION TOLERANCE $\pm 1/4"$.
- 3) RIGHT HAND UNIT SHOWN, LEFT HAND MIRROR IMAGE.

GENERAL DIMENSIONS				
MODEL	A	B	C	D
3HBC50	30-1/8	27-1/4	20-1/8	25-1/4
4HBC50	36-1/8	33-1/4	26-1/8	31-1/4
5HBC50	40-1/8	37-1/4	30-1/8	35-1/4
6HBC50	40-1/8	37-1/4	30-1/8	35-1/4
8HBC50	46-1/8	43-1/4	36-1/8	41-1/4
10HBC50	52-1/8	49-1/4	42-1/8	47-1/4
13HBC50	59-1/8	56-1/4	49-1/8	54-1/4

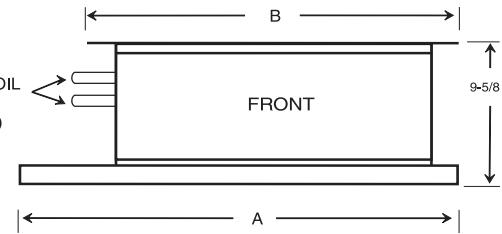
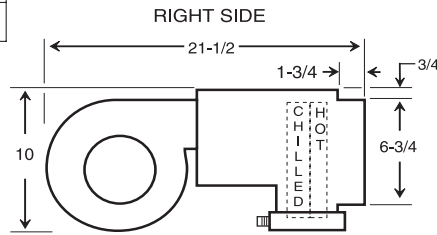
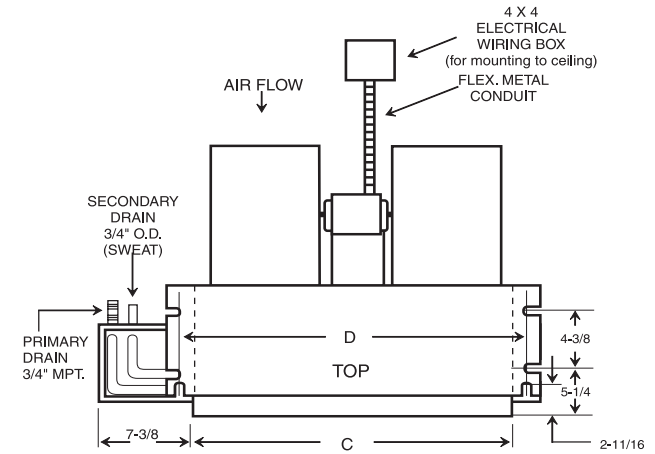

NOTE: RIGHT HAND MODEL SHOWN - LEFT HAND MODEL HAS DRAIN AND PIPING CONNECTIONS ON OPPOSITE SIDE OF FAN COIL.

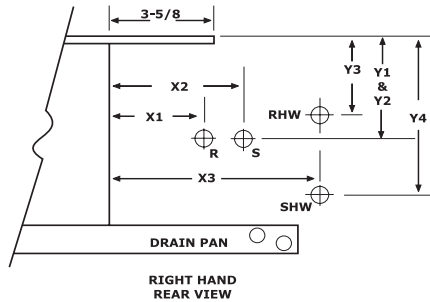

RIGHT HAND REAR VIEW

4 - PIPE UNIT SHOWN

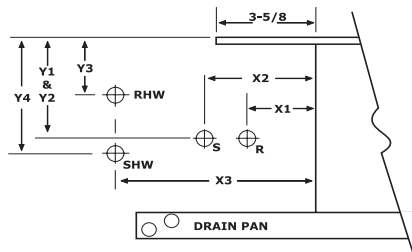

LEFT HAND REAR VIEW

HBC50 HEADER LOCATIONS							
RIGHT HAND	X1	Y1	X2	Y2	X3	Y3	Y4
3 ROW	3	4-1/4	5	4	---	---	---
3/1 Split	3	4-1/4	5	4	8	3-1/2	5-1/2
3/2 Split	3	4-1/4	5	4	8	3-1/2	5-1/2
4 ROW	3	4-1/4	5	4	---	---	---
4/1 Split	3	4-1/4	5	4	8	4	6

HBC50 HEADER LOCATIONS							
LEFT HAND	X1	Y1	X2	Y2	X3	Y3	Y4
3 ROW	3	3-3/4	5	4	---	---	---
3/1 Split	3	3-3/4	5	4	8	2-1/2	4-1/2
3/2 Split	3	3-3/4	5	4	8	2-1/2	4-1/2
4 ROW	3	3-3/4	5	4	---	---	---
4/1 Split	3	3-3/4	5	4	8	2	4

PRODUCT DRAWING:

FAN COIL UNITS
 MODEL **HBC50**
 NOT FOR CONSTRUCTION

Project Name:
 Location:
 Engineer:
 Contractor:
 For: REFERENCE

Sold To:
 Cust Purch Order #:

Quote Date:
 Rev. Date:
 Form No.:
 Dwg. Lev.:
 Dwg. Scale: NTS



NOTES:

- 1) ALL DIMENSIONS IN INCHES.
- 2) COIL CONNECTION TOLERANCE $\pm 1/4"$.
- 3) RIGHT HAND UNIT SHOWN, LEFT HAND MIRROR IMAGE.

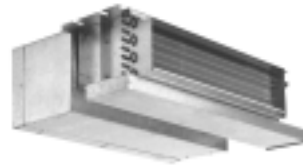

GENERAL DIMENSIONS							
MODEL	A	B	C	D	E	FILTER SIZE (INCL)	CONNECTIONS PRIMARY O.D.
3PHBC50	24	22	20-1/8	36-1/8	27-1/4	10 X 24	5/8"
4PHBC50	30	28	26-1/8	40-1/8	33-1/4	10 X 30	
5PHBC50	34	32	30-1/8	40-1/8	37-1/4	10 X 34	
6PHBC50	34	32	30-1/8	46-1/8	37-1/4	10 X 34	
8PHBC50	40	38	36-1/8	52-1/8	43-1/4	10 X 40	
10PHBC50	46	44	42-1/8	59-1/8	49-1/4	10 X 46	
13PHBC50	53	51	49-1/8		56-1/4	10 X 53	

NOTES:

- 1. Return plenums are insulated.
- 2. All plenums include throw-away filter.
- 3. Standard plenums are end return and can be field converted to bottom return.
- 4. Filter has separate filter access panel for easier service.

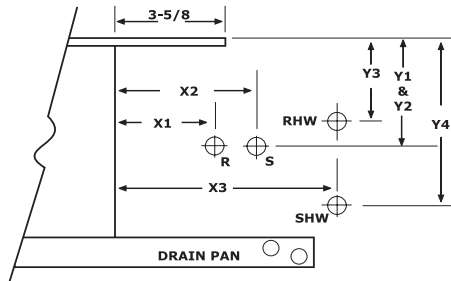
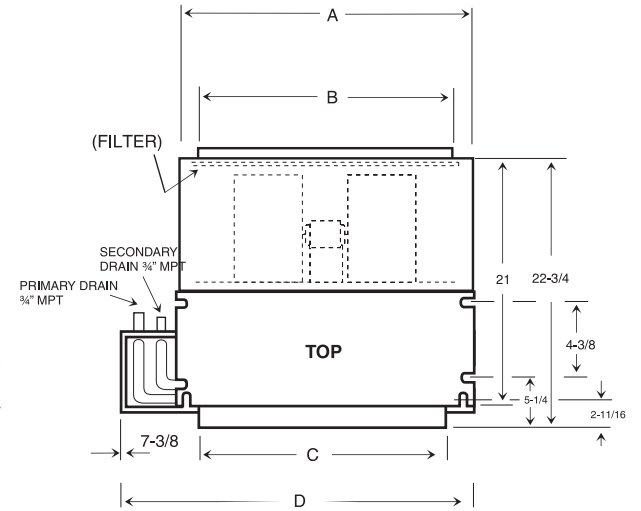

RIGHT HAND REAR VIEW

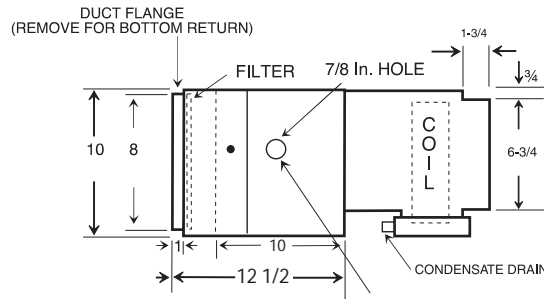

LEFT SIDE

ELECTRICAL KNOCKOUTS LOCATED EACH END AND ONE ON CENTER OF UNIT

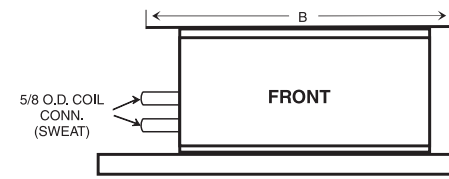

NOTE: RIGHT HAND MODEL SHOWN - LEFT HAND MODEL HAS DRAIN AND PIPING CONNECTIONS ON OPPOSITE SIDE OF FAN COIL.

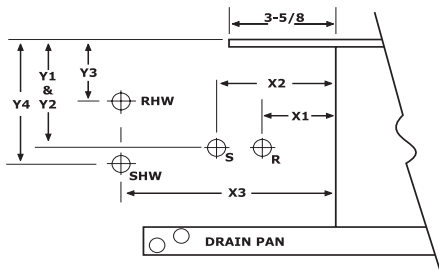

LEFT HAND REAR VIEW

PHBC50 HEADER LOCATIONS

RIGHT HAND	X1	Y1	X2	Y2	X3	Y3	Y4
3 ROW	3	4-1/4	5	4	---	---	---
3/1 Split	3	4-1/4	5	4	8	3-1/2	5-1/2
3/2 Split	3	4-1/4	5	4	8	3-1/2	5-1/2
4 ROW	3	4-1/4	5	4	---	---	---
4/1 Split	3	4-1/4	5	4	8	4	6

PHBC50 HEADER LOCATIONS

LEFT HAND	X1	Y1	X2	Y2	X3	Y3	Y4
3 ROW	3	3-3/4	5	4	---	---	---
3/1 Split	3	3-3/4	5	4	8	2-1/2	4-1/2
3/2 Split	3	3-3/4	5	4	8	2-1/2	4-1/2
4 ROW	3	3-3/4	5	4	---	---	---
4/1 Split	3	3-3/4	5	4	8	2	4

PRODUCT DRAWING:

FAN COIL UNITS
 MODEL PHBC50
 NOT FOR CONSTRUCTION

Project Name:
 Location:
 Engineer:
 Contractor:
 For: REFERENCE

Sold To:
 Cust Purch Order #:

Quote Date:
 Rev. Date:
 Form No.:
 Dwg. Lev.:
 Dwg. Scale: NTS



NOTES:

- 1) ALL DIMENSIONS IN INCHES.
- 2) COIL CONNECTION TOLERANCE $\pm 1/4"$.
- 3) RIGHT HAND UNIT SHOWN, LEFT HAND MIRROR IMAGE.

RIGHT SIDE

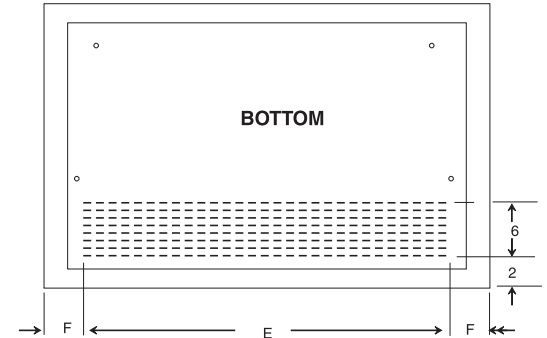
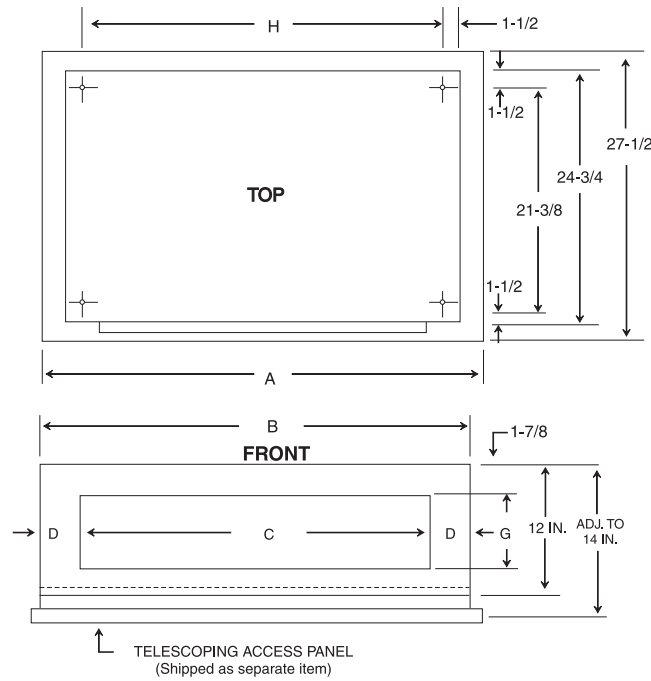
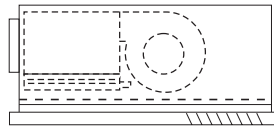

BACK

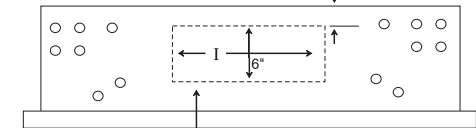

LANCED FOR FIELD REMOVAL FOR REAR RETURN AIR

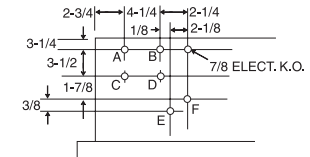

DETAIL OF BACK PANEL

- A - Hot water out ***
- B - Chilled water in LH unit**
Chilled water out RH unit
- C - Hot water in ***
- D - Chilled water out LH unit**
Chilled water in RH unit
- E - Primary drain**
- F - Secondary drain**
- All 1-1/2 Dia. K.O.'s**
- * 4-Pipe system only**

NOTES:

1. Telescoping panel allows the cabinet to be installed to within 2 inches of the ceiling line. The adjustable panel frame ensures a flush installation.
2. Louvered access panel (bottom return) is standard. Specify solid panel if ducted rear return air is required.

GENERAL DIMENSIONS

MODEL	A	B	C	D	E	F	G	H	I	TELESCOPING LOUVERED ACCESS PANEL	TELESCOPING SOLID ACCESS PANEL	FILTER SIZE (INCL)
3RHBC50	41	38-3/8	29	4-1/2	36-5/8	1-7/16	5-1/2	35	14	968-1	968-1S	10 X 37
4RHBC50	47	44-3/8	35	4-1/2	41-3/4	1-7/16	5-1/2	41	20	968-2	968-2S	10 X 43
5RHBC50	51	48-3/8	39	4-1/2	47-1/4	1-1/8	5-1/2	45	24	968-3	968-3S	10 X 43
6RHBC50	51	48-3/8	39	4-1/2	47-1/4	1-1/8	5-1/2	45	24	968-3	968-3S	10 X 43
8RHBC50	57	54-3/8	45	4-1/2	52-1/2	1-7/16	5-1/2	51	30	968-4	968-4S	10 X 53
10RHBC50	67	60-3/8	51	4-1/2	57-7/8	1-13/16	5-1/2	57	36	968-5	968-5S	10 X 59
13RHBC50	70	67-3/8	58	4-1/2	63-1/8	2-11/16	5-1/2	64	42	968-6	968-6S	10 X 65

PRODUCT DRAWING:

FAN COIL UNITS
MODEL RHBC50
NOT FOR CONSTRUCTION

Project Name:
Location:
Engineer:
Contractor:
For: REFERENCE

Sold To:
Cust Purch Order #:

Quote Date:
Rev. Date:
Form No.:
Dwg. Lev.:
Dwg. Scale: NTS



NOTES:

- 1) ALL DIMENSIONS IN INCHES.
- 2) COIL CONNECTION TOLERANCE $\pm 1/4"$.
- 3) RIGHT HAND UNIT SHOWN, LEFT HAND MIRROR IMAGE.

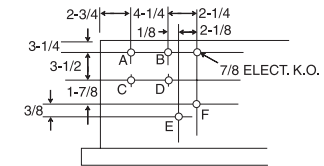
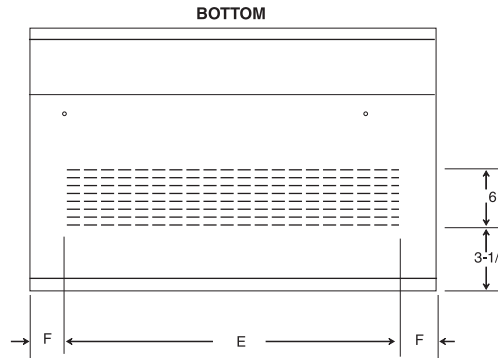
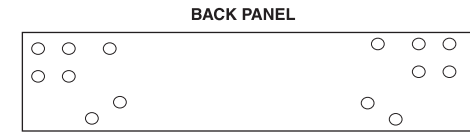
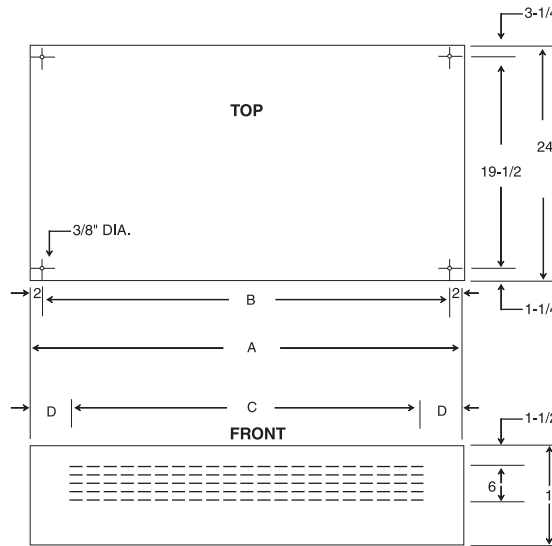
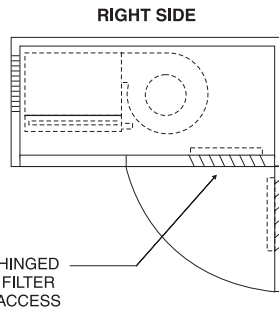

DETAIL OF BACK PANEL

- A - Hot water out *
 - B - Chilled water in LH unit
Chilled water out RH unit
 - C - Hot water in *
 - D - Chilled water out LH unit
Chilled water in RH unit
 - E - Primary drain
 - F - Secondary drain
- All 1-1/2 Dia. K.O.'s
* 4 - Pipe system only

NOTES:

- 1. Side panels are removable for easier valve access.
- 2. Plastic thumb screws are provided for easy filter access.

GENERAL DIMENSIONS								
MODEL	A	B	C	D	E	F	FILTER SIZE (INCL)	CONNECTIONS PRIMARY O.D.
3CHBC50	38	34	26	6	31-1/2	3-1/2	10 X 37	5/8"
4CHBC50	44	40	31-1/2	6	37	3-1/2	10 X 43	
5CHBC50	48	44	37	5-1/2	42-1/2	3	10 X 43	
6CHBC50	48	44	37	5-1/2	42-1/2	3	10 X 43	
8CHBC50	54	50	42-1/2	6	48	3	10 X 53	
10CHBC50	60	56	48	6	53	3-1/2	10 X 59	
13CHBC50	67	63	53	7	58-1/2	4	10 X 65	

PRODUCT DRAWING:

FAN COIL UNITS
MODEL **CHBC50**
NOT FOR CONSTRUCTION

Project Name:
Location:
Engineer:
Contractor:
For: REFERENCE

Sold To:
Cust Purch Order #:

Quote Date:
Rev. Date:
Form No.:
Dwg. Lev.:
Dwg. Scale: NTS



Cooling Capacity

***HBC50-3 (3-Row Coil)** All capacities are based on nominal CFM.

COOLING CAPACITY (1000 BTUH)																
MODEL	45°F ENTERING WATER								42°F ENTERING WATER							
	GPM	P.D. (FT. WTR.)	80°F D.B. (67°F W.B.)			75°F D.B. (63°F W.B.)			GPM	P.D. (FT. WTR.)	80°F D.B. (67°F W.B.)			75°F D.B. (63°F W.B.)		
			TH	SH	TR	TH	SH	TR			TH	SH	TR	TH	SH	TR
3*HBC50-3	2.8	11.1	10.7	7.4	7.6	8.2	6.4	5.8	3.1	13.3	11.9	7.8	7.7	9.1	6.8	5.9
	2.1	6.6	10.0	7.1	9.5	7.6	6.2	7.3	2.3	7.7	11.2	7.5	9.7	8.5	6.6	7.4
	1.6	4.0	9.3	6.8	11.6	7.1	6.0	8.8	1.8	5.0	10.5	7.3	11.6	8.0	6.3	8.9
	1.3	2.7	8.5	6.6	13.1	6.5	5.8	10.0	1.4	3.1	9.6	7.0	13.7	7.3	6.1	10.5
4*HBC50-3	3.6	20.2	14.4	9.9	8.0	11.0	8.6	6.1	4.0	24.3	16.0	10.5	8.0	12.2	9.1	6.1
	2.8	13.0	13.6	9.6	9.7	10.4	8.3	7.4	3.1	15.6	15.2	10.2	9.8	11.6	8.8	7.5
	2.1	7.9	12.5	9.1	11.9	9.5	8.0	9.1	2.4	9.9	14.2	9.8	11.8	10.8	8.5	9.0
	1.7	5.4	11.5	8.8	13.5	8.8	7.7	10.3	1.9	6.6	13.1	9.4	13.8	10.0	8.2	10.6
5*HBC50-3	4.5	8.1	16.9	11.9	7.5	12.9	10.4	5.7	5.0	9.8	18.9	12.6	7.5	14.4	10.9	5.8
	3.3	4.6	15.6	11.4	9.4	11.9	9.9	7.2	3.7	5.6	17.6	12.1	9.5	13.4	10.6	7.3
	2.6	2.9	14.2	10.9	10.9	10.9	9.6	8.3	2.9	3.6	16.2	11.6	11.2	12.4	10.1	8.5
	2.9	2.0	12.9	10.4	12.3	9.9	9.2	9.4	2.4	2.5	15.0	11.1	12.5	11.4	9.8	9.5
6*HBC50-3	5.7	12.5	20.4	14.1	7.1	15.6	12.3	5.5	6.3	15.1	22.6	14.9	7.2	17.3	12.9	5.5
	4.3	7.4	19.1	13.6	8.9	14.6	11.9	6.8	4.7	8.8	21.3	14.4	9.0	16.2	12.5	6.9
	3.3	4.6	17.6	13.0	10.7	13.4	11.4	8.2	3.7	5.6	20.0	13.9	10.8	15.3	12.1	8.3
	2.7	3.1	16.2	12.5	12.0	12.4	11.0	9.2	3.0	3.8	18.5	13.4	12.3	14.1	11.7	9.4
8*HBC50-3	6.4	13.3	24.6	17.6	7.7	18.8	15.4	5.9	7.2	16.5	17.6	18.7	7.7	21.1	16.3	5.9
	4.7	7.5	22.7	16.9	9.6	17.3	14.8	7.4	5.3	9.3	25.6	18.0	9.6	19.5	15.7	7.4
	3.7	4.8	20.6	16.1	11.1	15.7	14.2	8.5	4.2	6.1	23.7	17.3	11.3	18.1	15.1	8.6
	2.9	3.0	18.4	15.3	12.7	15.6	14.0	10.8	3.3	3.9	21.3	16.4	12.9	16.3	14.5	9.9
10HBC50-3	8.4	19.8	30.7	21.8	7.3	23.4	19.1	5.6	9.6	15.8	34.5	23.2	7.2	26.3	21.2	5.5
	6.0	10.1	27.9	20.8	9.3	21.3	18.3	7.1	6.8	12.9	31.6	22.2	9.3	24.1	19.4	7.1
	4.6	5.9	25.3	19.8	11.0	19.3	17.5	8.4	5.2	7.6	28.9	21.2	11.1	22.1	18.6	8.5
	3.7	3.8	22.8	18.9	12.3	18.5	16.9	10.4	4.2	4.9	26.4	20.2	12.6	20.2	17.9	9.6
13*HBC50-3	10.8	32.2	39.2	27.7	7.3	29.9	24.3	5.5	12.4	41.8	43.7	29.4	7.0	33.4	25.6	5.4
	7.8	17.3	36.1	26.6	9.3	27.6	23.4	7.1	8.8	21.8	40.7	28.3	9.3	31.1	24.7	7.1
	6.0	10.5	33.2	25.5	11.1	25.4	22.5	5.8	6.8	13.4	37.8	27.2	11.1	28.8	23.9	8.5
	4.8	6.9	30.3	24.5	12.6	23.1	21.7	9.6	5.5	8.9	35.1	26.2	12.7	26.8	23.1	9.7

TH - Total Cooling Capacity SH - Sensible Cooling Capacity TR - Water temp. rise * - P - with insulated return plenum
 - R - recessed with telescoping panel
 - C - cabinet exposed

Heating Capacity

***HBC50-3 (3-Row Coil)**

HEATING CAPACITY (1000 BTUH)						
MODEL	GPM	P.D. (FT. WTR.)	ENTERING WATER TEMP.			
			180°F	160°F	140°F	120°F
3*HBC50-3	3.0	12.6	26.9	22.0	17.1	12.2
	2.0	6.0	26.0	21.2	16.5	11.8
	1.0	1.7	23.4	19.1	14.9	10.6
4*HBC50-3	3.5	19.3	35.8	29.3	22.8	16.3
	2.5	10.7	34.6	28.3	22.0	15.7
	1.5	4.4	32.1	26.3	20.4	14.6
5*HBC50-3	4.0	6.5	42.7	35.0	27.2	19.4
	3.0	3.8	41.3	33.8	26.3	18.8
	2.0	1.8	38.6	31.6	24.6	17.5
6*HBC50-3	5.5	11.7	50.1	41.0	31.9	22.8
	4.0	6.5	48.6	39.7	30.9	22.1
	2.5	2.7	45.4	37.1	28.9	20.6
8*HBC50-3	6.0	11.8	64.0	52.4	40.7	29.1
	4.5	6.9	61.9	50.6	39.4	28.1
	3.0	3.2	57.7	47.2	36.7	26.2
10*HBC50-3	8.0	17.9	79.2	64.8	50.4	36.0
	6.0	10.1	76.6	62.7	48.8	34.8
	4.0	4.5	71.9	58.8	45.7	32.7
13*HBC50-3	10.0	27.8	100.8	82.4	64.1	45.8
	7.5	16.1	97.8	80.0	62.2	44.5
	5.0	17.4	92.0	75.3	58.5	41.8

NOTES:

1. Ratings at 70 degree ent. air temp.
2. Contact factory for capacities at other conditions

* - P - with insulated return plenum
 - R - recessed with telescoping panel
 - C - cabinet exposed

Cooling Capacity

*HBC50-4 (4-Row Coil) All capacities are based on nominal CFM.

COOLING CAPACITY (1000 BTUH)																
MODEL	45°F ENTERING WATER								42°F ENTERING WATER							
	GPM	P.D. (FT. WTR.)	80°F D.B. (67°F W.B.)			75°F D.B. (63°F W.B.)			GPM	P.D. (FT. WTR.)	80°F D.B. (67°F W.B.)			75°F D.B. (63°F W.B.)		
			TH	SH	TR	TH	SH	TR			TH	SH	TR	TH	SH	TR
3*HBC50-4	2.4	10.6	11.4	7.8	9.5	8.7	6.8	7.3	2.6	12.2	12.6	8.3	9.7	9.7	7.2	7.4
	1.8	6.3	10.6	7.5	11.8	8.1	6.5	9.0	2.1	8.3	12.0	8.0	11.4	9.2	7.0	8.7
	1.5	4.5	10.0	7.2	13.3	7.6	6.3	10.1	1.7	5.6	11.3	7.8	13.3	8.7	6.8	10.2
	1.2	3.0	9.1	6.9	15.1	6.9	6.1	11.5	1.4	4.0	10.6	7.5	15.1	8.1	6.5	11.5
4*HBC50-4	3.3	21.5	15.6	10.5	9.4	11.9	9.1	7.2	3.6	25.1	17.3	11.2	9.6	13.2	9.7	7.3
	2.5	13.2	14.5	10.1	11.6	11.1	8.8	8.9	2.8	16.1	16.3	10.8	11.7	12.5	9.4	8.9
	2.0	8.9	13.5	9.7	13.5	10.3	8.5	10.3	2.3	11.4	15.4	10.5	13.4	11.8	9.1	10.2
	1.6	6.0	12.3	9.3	15.4	9.4	8.2	11.8	1.8	7.4	14.2	10.0	15.8	10.8	8.7	12.0
5*HBC50-4	3.8	7.6	18.0	12.5	9.5	13.7	10.9	7.2	4.2	9.1	20.0	13.3	9.5	15.3	11.6	7.3
	3.0	4.9	16.6	12.0	11.1	12.7	10.5	8.5	3.3	5.8	18.7	12.8	11.4	14.3	11.2	8.7
	2.4	3.2	15.2	11.5	12.6	11.6	10.1	9.7	2.7	4.0	17.4	12.3	12.9	13.3	10.7	9.8
	2.0	2.3	13.9	11.0	13.9	10.6	9.7	10.6	2.3	3.0	16.2	11.9	14.1	12.4	10.4	10.8
6*HBC50-4	4.7	11.2	21.6	14.9	9.2	16.5	13.0	7.0	5.3	14.0	24.2	15.9	9.1	18.5	13.8	7.0
	3.7	7.2	20.4	14.4	11.0	15.5	12.6	8.4	4.1	8.7	22.8	15.4	11.1	17.4	13.4	8.5
	3.0	4.9	18.8	13.9	12.5	14.4	12.2	9.6	3.4	6.2	21.5	14.9	12.7	16.4	13.0	9.7
	2.5	3.5	17.4	13.3	13.9	13.3	11.7	10.6	2.8	4.3	19.9	14.3	14.2	15.2	12.5	10.9
8*HBC50-4	5.8	13.9	26.7	19.0	9.2	20.4	16.6	7.0	6.5	16.9	30.0	20.2	9.2	22.9	17.6	7.0
	4.5	8.9	24.8	18.3	11.0	19.0	16.0	8.4	5.0	10.7	28.0	19.5	11.2	21.4	17.0	8.6
	3.7	6.3	22.9	17.6	12.4	17.5	15.5	9.5	4.1	7.6	26.1	18.7	12.7	19.9	16.4	9.7
	3.1	4.6	21.1	16.9	13.6	16.1	14.9	10.4	3.4	5.4	24.1	18.0	14.2	18.4	15.8	10.8
10HBC50-4	6.9	13.7	32.5	23.3	9.4	24.8	20.3	7.2	7.9	17.8	36.7	24.9	9.3	28.1	21.6	7.1
	5.3	8.3	29.8	22.3	11.3	22.8	19.6	8.6	6.0	10.5	33.9	23.8	11.3	25.9	20.8	8.6
	4.3	5.6	27.3	21.3	12.7	20.9	18.8	9.7	4.8	6.9	31.3	22.8	13.0	23.9	20.0	10.0
	3.5	3.8	24.7	20.4	14.1	20.5	18.4	11.7	4.0	4.9	28.8	21.9	14.4	22.0	19.3	11.0
13*HBC50-4	8.9	25.5	42.0	29.9	9.4	32.0	26.1	7.2	10.0	31.8	47.1	36.8	9.4	35.9	27.7	7.2
	6.8	15.3	38.8	28.7	11.4	29.6	25.2	8.7	7.6	18.9	43.8	30.6	11.5	33.4	26.7	8.8
	5.5	10.2	36.0	27.7	13.1	27.5	24.4	10.2	6.2	12.8	41.0	29.5	13.2	31.3	25.8	10.1
	4.6	7.3	33.3	26.7	14.7	25.4	23.6	11.0	5.1	8.8	38.0	28.4	14.9	29.0	25.0	11.4

TH - Total Cooling Capacity

SH - Sensible Cooling Capacity

TR - Water temp. rise

Heating Capacity

*HBC50-4 (4-Row Coil)

HEATING CAPACITY (1000 BTUH)						
MODEL	GPM	P.D. (FT. WTR.)	ENTERING WATER TEMP.			
			180°F	160°F	140°F	120°F
3*HBC50-4	3.0	15.9	28.6	23.4	18.2	13.0
	2.0	7.6	27.6	22.6	17.6	12.6
	1.0	2.2	24.9	20.3	15.8	11.3
4*HBC50-4	3.5	23.9	38.1	31.1	24.2	17.3
	2.5	13.2	36.8	30.1	23.4	16.7
	1.5	5.3	34.2	28.0	21.8	15.5
5*HBC50-4	4.0	8.3	45.6	37.3	29.0	20.7
	3.0	4.9	44.0	36.0	28.0	20.0
	2.0	2.3	41.2	33.7	26.2	18.7
6*HBC50-4	5.5	15.0	53.7	43.9	34.1	24.4
	4.0	6.5	51.1	51.8	32.5	23.2
	2.5	3.5	48.6	39.8	30.9	22.1
8*HBC50-4	6.0	14.7	68.8	56.3	43.8	31.3
	4.5	8.9	66.4	54.3	42.3	30.2
	3.0	4.4	62.0	50.7	39.4	28.2
10*HBC50-4	8.0	18.2	85.3	69.8	54.3	38.8
	6.0	10.5	82.5	67.5	52.5	37.5
	4.0	4.9	77.3	63.3	49.2	35.1
13*HBC50-4	10.0	31.8	108.8	89.0	69.2	49.4
	7.5	18.4	105.6	86.4	67.2	48.0
	5.0	8.5	99.3	81.2	63.2	45.1

NOTES:

1. Ratings at 70 degree ent. air temp.
2. Contact factory for capacities at other conditions

- * - P - with insulated return plenum
- R - recessed with telescoping panel
- C - cabinet exposed

Heating Capacity

-HBC50 31, 41, and 32 (4-pipe application)

HEATING CAPACITY ⁽²⁾ (1000 BTUH)												
MODEL	1-ROW COIL (*HBC-31 AND *HBC-41)						2-ROW COIL (*HBC-32)					
	GPM	P.D. (FT. WTR)	ENTERING WATER TEMP.				GPM	P.D. (FT. WTR.)	ENTERING WATER TEMP.			
			180°F	160°F	140°F	120°F			180°F	160°F	140°F	120°F
3*HBC50	1.0	3.2	13.9	11.4	8.8	6.3	1.0	1.5	15.9	13.0	10.1	7.2
	2.0	11.3	15.2	12.4	9.6	6.9	2.0	5.1	17.7	14.5	11.2	8.0
	3.0	23.6	15.5	12.7	9.9	7.1	3.0	10.5	18.3	15.0	11.7	8.3
4*HBC50	1.0	4.5	17.5	14.4	11.2	8.0	1.0	1.5	19.9	16.4	12.7	9.1
	2.0	14.4	19.6	16.1	12.5	8.9	2.0	5.4	22.8	18.7	14.5	10.4
	3.0	30.8	24.1	19.8	15.4	11.0	3.0	11.2	24.0	19.6	15.2	10.9
5*HBC50	1.0	4.4	20.4	16.7	13.0	9.3	1.0	1.9	23.4	19.1	14.9	10.6
	2.0	15.0	23.3	19.1	14.8	10.6	2.0	6.4	27.2	22.3	17.3	12.4
	3.0	30.8	24.1	19.8	15.4	11.0	3.0	13.4	28.8	23.5	18.3	13.1
6*HBC50	1.0	4.4	22.4	18.3	14.2	10.2	1.0	1.9	25.8	21.1	16.4	11.7
	2.0	15.0	25.7	21.0	16.4	11.7	2.0	6.4	30.3	24.8	19.3	13.8
	3.0	30.8	26.8	21.9	17.0	12.2	3.0	13.4	32.1	26.2	20.4	14.6
8*HBC50	1.0	5.5	26.8	21.9	17.0	12.2	1.0	0.6	29.3	24.0	18.7	13.3
	2.0	18.8	31.6	25.9	20.1	14.4	2.0	2.2	35.4	28.9	22.5	16.1
	3.0	39.3	39.3	32.1	25.0	17.9	3.0	4.8	38.6	31.6	24.6	17.5
10*HBC50	1.0	6.2	30.8	25.2	19.6	14.0	1.0	0.6	29.3	24.0	18.7	13.3
	2.0	19.9	37.0	30.3	23.5	16.8	2.0	2.2	41.3	33.8	26.3	17.5
	3.0	39.3	39.3	32.1	25.0	17.9	3.0	4.7	45.7	37.4	29.1	20.8
13*HBC50	1.0	6.8	36.9	30.2	23.5	16.8	1.0	0.4	39.9	32.6	25.4	18.1
	2.0	23.4	44.2	36.1	28.1	20.1	2.0	1.9	49.2	40.3	31.3	22.4
	3.0	48.1	47.3	38.7	30.1	21.5	3.0	4.3	55.0	45.0	35.0	25.0

NOTES:

1. Ratings at 70°F entering air temperature.
2. Contact factory for capacities at other conditions

- * - P - with insulated return plenum
- R - recessed with telescoping panel
- C - cabinet exposed

COOLING CAPACITY CORRECTION FACTORS														
MODEL	3HBC50		4HBC50		5HBC50		6HBC50		8HBC50		10HBC50		13HBC50	
CFM	TH	SH	TH	SH	TH	SH	TH	SH	TH	SH	TH	SH	TH	SH
150	.70	.64												
175	.75	.70												
200	.80	.76												
225	.85	.82												
250	0.9	.88	.70	.64										
300	1.00	1.00	.76	.71	.70	.64								
325	1.04	1.06	.79	.75	.72	.67								
350	1.10	1.12	.82	.78	.75	.70	.69	.63						
400			.88	.86	.80	.76	.73	.68						
450			.94	.93	.85	.82	.77	.73	.71	.66				
500			1.00	1.00	.90	.88	.81	.77	.74	.69				
550			1.06	1.07	.95	.94	.85	.82	.78	.73	.71	.65		
600			1.12	1.14	1.00	1.00	.89	.87	.81	.78	.74	.68		
700					1.10	1.12	.98	.98	.88	.85	.79	.75	.70	.64
800							1.05	1.06	.95	.94	.85	.82	.74	.69
900							1.14	1.16	1.02	1.02	.90	.88	.78	.74
1000									1.09	1.11	.96	.95	.83	.79
1100									1.15	1.18	1.02	1.02	.87	.85
1200											1.07	1.09	.92	.90
1300											1.12	1.14	1.06	1.05
1400													1.00	1.00
1500													1.04	1.05

TH - Total Heat SH - Sensible Heat



VALVE CLUSTERS AND INDIVIDUAL COMPONENTS: (field installed) - For (R,P,C)HBC50		
Assembled Valve Clusters: (factory-assembled and field installed) Components are factory piped together (order power heads separately). Contact factory for other valve clusters.		
Right Hand	Left Hand	Description (all 1/2")
9VHR2BV	9VHL2BV	2-pipe, 2 hand valves only
9VHR22B	9VHL22B	2-pipe, one 2-way valve body and 2 hand valves
9VHR23B	9VHL23B	2-pipe, one 3-way valve body and 2 hand valves
9VHR4BV	9VHL4BV	4-pipe, 4 hand valves only
9VHR42B	9VHL42B	4-pipe, two 2-way valve bodies and 4 hand valves
9VHR43B	9VHL43B	4-pipe, two 3-way valve bodies and 4 hand valves
Power Heads: (one power head required for each valve body) - For all units		
E50138180		220V/50 Hz – 230V/60 Hz
Separate Valve Bodies: (order power heads separately)		
E421213		1/2" 2-way - For (R,P,C)HBC
E431213		1/2" 3-way - For (R,P,C)HBC
Hand Valves: (Combination balance / shut-off) (2 usually req'd per coil)		
CP9		1/2"

(1) 4-pipe, 3-way, left hand, 220V **assembled valve package** =

One # 9VHL43B assembled valve cluster

Two # E50138180 power heads

(2) 4-pipe, 3-way, left hand, 220V (1/2") **separate components** =

Two # E431213 1/2" 3-way bodies

Two # E50138180 power heads

Four # CP9 hand valves

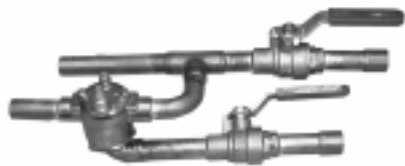

Assembled Valve Cluster (2-way)

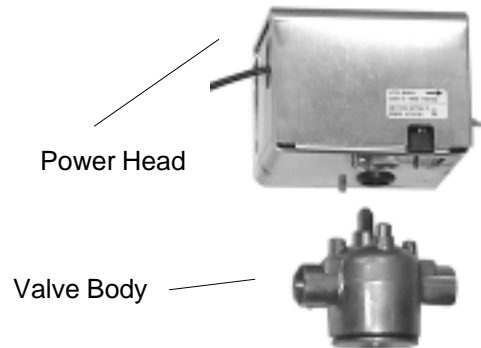

Power Head

Valve Body



CP90

Guide Specifications

Furnish and install fan coil units as indicated on the plans.

Units shall be certified to deliver published capacities when tested in accordance with latest ARI Standard 440.

Units shall be complete with water coil, one or more centrifugal fans, condensate drain pan, and galvanized steel casing.

Coils shall be (3-row) (4-row) (4-row split) (5-row split) with staggered 3/8 in. O.D. copper tubes mechanically bonded to aluminum fins with 5/8 in. O.D. copper tube connections. All coils shall be factory leak tested at 400 psig

minimum air pressure. Coils shall have manual air vents.

Motors shall be 3-speed permanent split capacitor type with built-in overload protection and sleeve bearings with oil tubes. Voltage is 220V/50Hz.

Drain pan shall be insulated with a U.L.Listed, closed cell, fire retardant foam insulation to prevent sweating. Primary drain connection shall be 3/4 in. MPT. Pan shall be furnished with 7/8 in. O.D. copper secondary overflow drain connection. All drain pans are sloped toward the drain connections to facilitate condensate removal.

Exposed units and panels shall have a baked on off-white finish.

CEILING ACCESS PANELS

PART NO	FRAME DIMENSIONS	TYPE	FOR FIRST CO. FAN COIL MODELS
965 965-1	27-1/2 X 43	LOUVERED SOLID	3,4,5,6HBC/PHBC
966 966-1	27-1/2 X 49	LOUVERED SOLID	8HBC/PHBC
967 967-1	27-1/2 X 55-1/2	LOUVERED SOLID	10HBC/PHBC
967-4 967-5	27-5/8 X 70-1/8	LOUVERED SOLID	13HBC/PHBC

- NOTES:**
1. Panels are surface mount and coated with white baked on epoxy paint.
 2. Filter clips are provided on louvered models (no filter).
 3. Panel doors are hinged.

