

# ENCLOSURE

## HX, HBC-HW, HBC-HWQ, CDXQ, CDX-HW

### INSTALLATION INSTRUCTIONS

#### **\*\*WARNING TO INSTALLER, SERVICE PERSONNEL AND OWNER\*\***

Altering the product or replacing parts with non authorized factory parts voids all warranty or implied warranty and may result in adverse operational performance and/or a possible hazardous safety condition to service personnel and occupants. Company employees and/or contractors are not authorized to waive this warning. Current **Maintenance Program** is available at [www.firstco.com](http://www.firstco.com) under "Product Information".

#### GENERAL

The manufacturer assumes no responsibility for equipment installed in violation of any code requirement.

These instructions give information relative to the installation of these enclosures only. For other related equipment refer to the proper instructions.

Material in this shipment has been inspected at the factory and released to the transportation agency in good condition. When received, a visual inspection of all cartons should be made immediately. Any evidence of rough handling or apparent damage should be noted on the delivery receipt and the material inspected in the presence of the carrier's representative. If damage is found, a claim should be filed against the carrier immediately.

#### ENCLOSURE MOUNTING

The installer must adhere strictly to all local and national code requirements pertaining to the installation of this equipment. These enclosures are designed to be installed in the ceiling for horizontal mounting only.

Location of the unit must be in an area providing adequate access to the ceiling panel since all components must be serviced from this area.

The enclosure should be lifted to the desired location and secured using the mounting holes located on the top with an acceptable mounting method (Figure 1). The enclosure must be level in both directions to permit proper drainage of the fan coil.

After the enclosure is mounted a 2x2 or 2x4 frame must be installed around the base of the enclosure to

create an air tight seal. Figure 7 shows a typical arrangement for the framing required.

#### **\*\*\*\*\* WARNING \*\*\*\*\***

**Extreme caution must be taken that no internal damage will result if screws or holes are drilled into the cabinet.**

#### INSTALLING FAN COIL UNIT INTO ENCLOSURE

1. Ensure that the enclosure has been installed level.
2. Remove motor/blower assembly from the fan coil.
3. Lift coil assembly into enclosure and place the top flange of the coil onto the top surface of the mounting angles at each end of the enclosure.
4. Slide coil assembly forward until the supply duct flanges of the fan coil are fully engaged into the front of the enclosure.

**NOTE: Before fastening, the fan coil unit must be fully engaged into the supply duct flange. If not, supply air may recirculate into the enclosure. To ensure total engagement, push the fan coil unit forward. Total engagement has occurred when the front of the top plate and the front of the drain pan are squeezing against the insulation.**

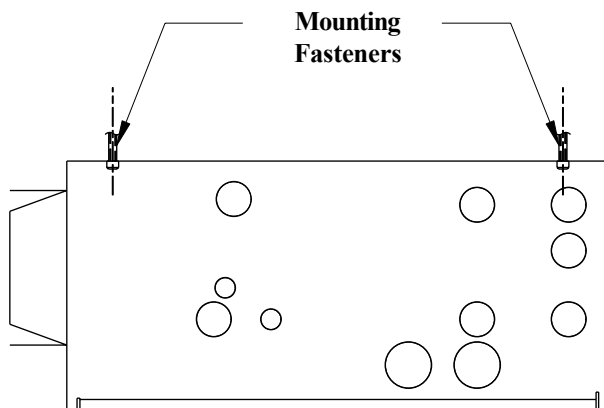

Figure 1

5. Fasten the coil assembly to the fan coil with sheetmetal screws through the slots in the mounting angle.
6. Install motor/blower assembly.
7. Check to make sure that the fan coil is level and that the drain pan will drain properly.

**\*\*\*\*\* WARNING \*\*\*\*\***

*It is recommended that the enclosure and fan coil be protected (covered) during the dry wall and painting process to prevent the spraying of the material into the enclosure and on the fan coil.*

### ENCLOSURE WITH FAN COIL FACTORY MOUNTED

On larger units, installation may be easier if the enclosure and unit are mounted separately. Unit removal is the reverse of the installation procedure above.

**NOTE:** *Before mounting the enclosure check to see if the fan coil unit is fully engaged into the supply duct flange. Total engagement is when the front of the top plate and the front of the drain pan are squeezing against the insulation. Also check to make*

***certain that the fan coil unit is secured firmly to the enclosure with sheetmetal screws through the mounting angle.***

Refer to enclosure mounting instructions on page one.

### CONNECTION OF AIR DISTRIBUTION DUCTS

All duct work must be installed in accordance with National Fire Protection Association Codes 90A and 90B. Since the return air to the unit is through louvers in the ceiling panel, applicable installation codes may limit the unit to installation only in single story residences.

The enclosure has supply duct flanges to accommodate the connection of a supply plenum, however extreme care must be taken to insure proper fastening of the supply plenum to the enclosure.

**\*\*\*\*\* WARNING \*\*\*\*\***

**The fan coil unit protrudes approximately 1-1/2 inches into the supply duct flanges on the enclosure. (Figure 5)**

The fastening of the supply plenum must be at least 1-3/4 inches away from the front edge of the enclosure. This prevents two problems: (1) If the enclosure is mounted without the fan

coil installed and the duct fasteners are too close to the front edge it will not permit the fan coil to engage completely. (2) If the enclosure and fan coil unit are mounted as an assembly and the duct fasteners are too close to the front edge they may also secure the flanges on the fan coil unit preventing the removal of the unit from the enclosure.

An optional return air cutout is supplied on the rear of the enclosure to permit ducted return and is shown in Figure 6. Rear entry ducted return requires the use of a solid ceiling panel.

**\*\*\*\*\* WARNING \*\*\*\*\***

**The fasteners securing the duct must be at least 1-3/4 inches away from the front edge of the enclosure.**

### ENTRY POINT CONNECTIONS

For general reference the following items are shown in Figure 6:

- optional return air plenum cutout
- entry points for connection to refrigerant lines, water coil, electrical lines, and drain lines.

Refer to individual fan coil installation instruction for specific piping and electrical wiring requirements.

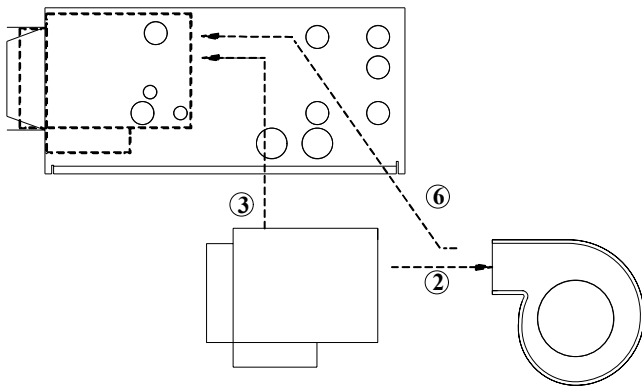
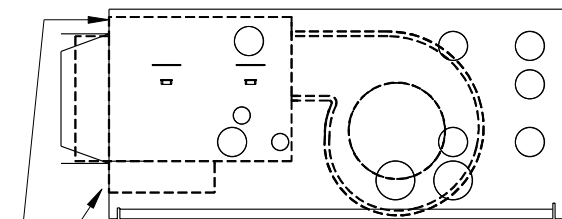

Figure 3



Total Engagement

Figure 4

---

## PLENUM AND UNIT FLANGE LOCATIONS

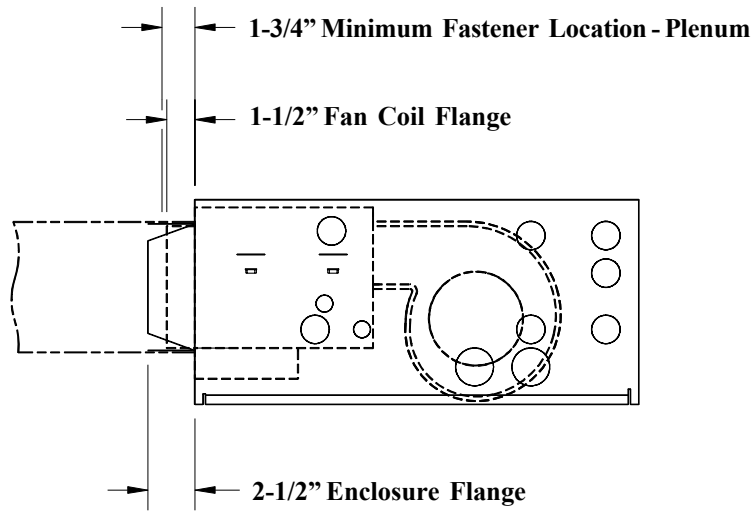

Figure 5

---

## CONNECTION LOCATIONS

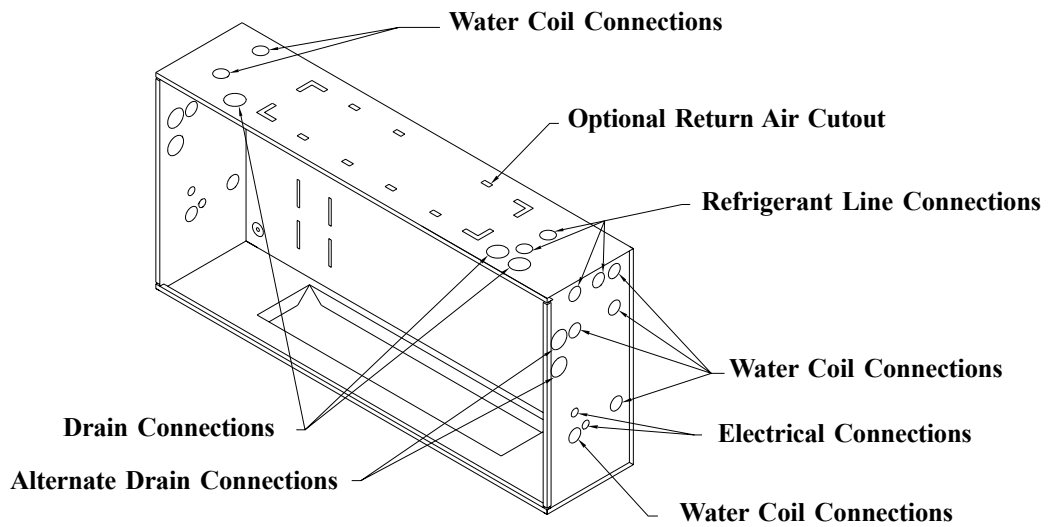

Figure 6

---

# CEILING PANEL INSTALLATION

*Ceiling panel assemblies are shipped separate to protect them from damage during shipping and installation.*

Figures 7 and 8 show details of the ceiling panel frame installation.

## INSTALLATION SUPPORT FRAMING

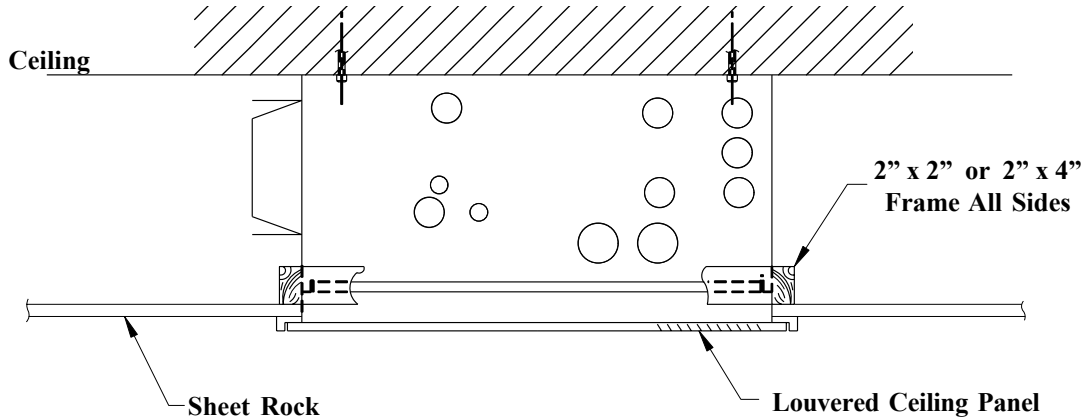

### Note:

Unit must be located such that the 2" x 2" or 2" x 4" frame creates an air tight seal around unit.

Figure 7

## CEILING PANEL FRAME INSTALLATION

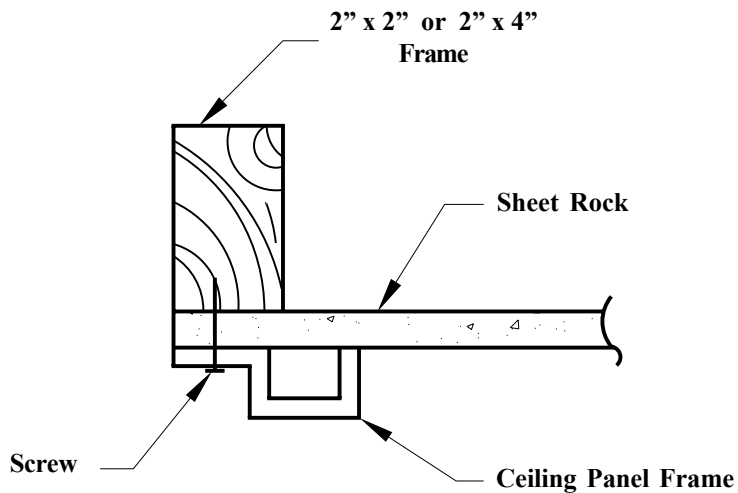

Figure 8