

# Aquatherm<sup>®</sup>



---

## INSTALLATION AND APPLICATION MANUAL FOR AQUATHERM<sup>®</sup> COMBO HEATERS

---

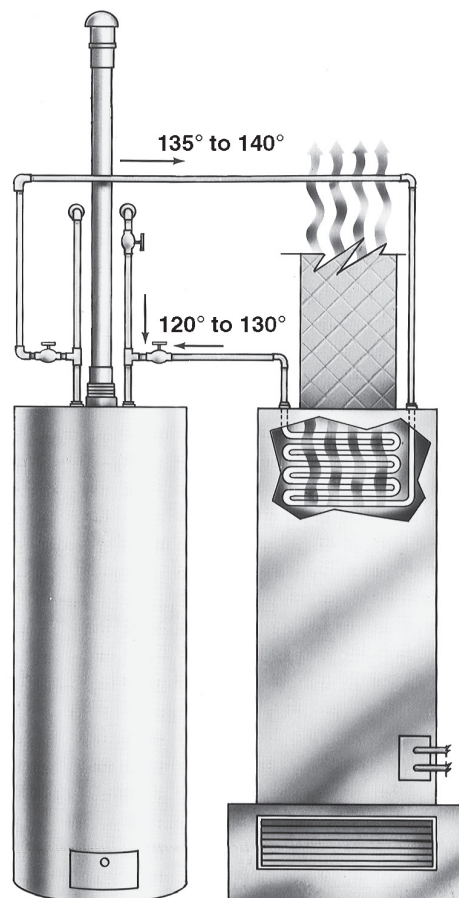

# Table of Contents

	Page
<b>Introduction</b> _____	3
<b>Sequence of Operation</b> _____	3
<b>General Description:</b>	
Air handler cabinet _____	3
Heating and cooling coils _____	3
Add-on hot water coil _____	3
Circulating pump _____	3
Flow control module _____	3
Check valve _____	3
Air purge valve _____	4
Blower door safety switch _____	4
Water heater _____	4
Boiler _____	4
<b>Accessories:</b>	
Thermostat _____	4
Freeze protector _____	4
<b>Equipment Sizing:</b>	
Condensing unit _____	4
Air handler _____	4
Water heater _____	5
<b>Installation:</b>	
Duct work _____	5
Electrical _____	5
Water piping _____	6
1. Material _____	6
2. Solder connections _____	6
3. Insulation _____	6
4. Length _____	6
5. Shut-off valves _____	6
6. Piping connections _____	6,8-10
Air handler _____	6
Flow control module _____	6
Water heater _____	6
Multiple water heaters _____	7
Anti-scald valve _____	7
<b>Start-up Procedure (heating cycle)</b> _____	7
<b>Troubleshooting</b> _____	12

The **Aquatherm®** is a First Co. air handler that converts a properly sized gas or oil-fired water heater into a highly efficient, dual - purpose appliance that can heat your home as well as provide hot water for domestic purposes.

**Any** properly sized water heater (for heating) and split system type condensing unit (for cooling) will work with First Co. **Aquatherm®** air handlers and are to be supplied by others. **NO SPECIAL WATER HEATER IS REQUIRED!**

**Aquatherm®** air handlers are even compatible with boiler systems.

**Aquatherm®** air handlers include a fan motor for air circulation, hot water circulating pump, hot water heating coil, air purge valve, check valve, components for low voltage control and most include a cooling coil for air conditioning. All components in the water piping meet NSF61 and/or california AB1953 requirements.

### SEQUENCE OF OPERATION (Heating mode)

When space heating is needed, the wall thermostat energizes a small pump which circulates hot water (135 to 140 degrees ) from the water heater to the hot water coil in the air handler. As the fan motor forces the cool return air from the home over the hot water coil, the air absorbs heat from the hot water and this warm air (about 105 to 110 degrees) is then circulated throughout the duct system and into the home.

**IMPORTANT.** . . . in most applications the water will lose only 15 to 25 degrees in temperature while circulating through the hot water coil and will **RETURN** to the water heater at about 115 to 125 degrees to be reheated.

### GENERAL DESCRIPTION

**Air handler cabinet:** Air handlers with cabinets are made of galvanized steel and fully insulated to reduce noise and maximize efficiency. Throwaway filters are factory installed in most air handlers.

**Heating and cooling coils:** All heating and cooling coils are made of copper tubes with mechanically bonded aluminum fins for maximum heat transfer. Manual air vents are included on all hot water coils. Cooling coils have either piston - type metering devices or field installed expansion valves. Primary and secondary condensate drain connections are provided on each cooling coil. All primary connections are 3/4 inch MPT.

**Add - on hot water coil:** First Co. HWC series add-on hot water coils are designed to be installed in either existing or new duct work and operate in conjunction with the existing fan motor to provide complete or supplemental space heating from a gas or oil - fired water heater. These coils are completely cased and utilize the separate “flow control module” which can be installed at the water heater for easy access and service (see “flow control module”).

**Circulating pump:** All circulating pumps circulate water at a rate of 3 to 6 gallons per minute and are either factory installed or included as part of the field installed “flow control module”. These pumps are designed to circulate a precise amount of hot water between the water heater and air handler or add - on coil.

**Flow control module:** This U.L. Listed device consists of the circulating pump, check valve, air purge valve, 6' plug - in line cord and pump relay. The module is sold & shipped separately with HWC add - on hot water coils. The module can be field installed anywhere in the hot water heating loop between the water heater and hot water coil and offers the advantage of being able to install the pump assembly in the most appropriate location for service and maintenance. Modules must be installed with the motor in a horizontal position. Junction box should **not** be located underneath the pump.

#### FLOW CONTROL MODULE - WIRING DIAGRAM

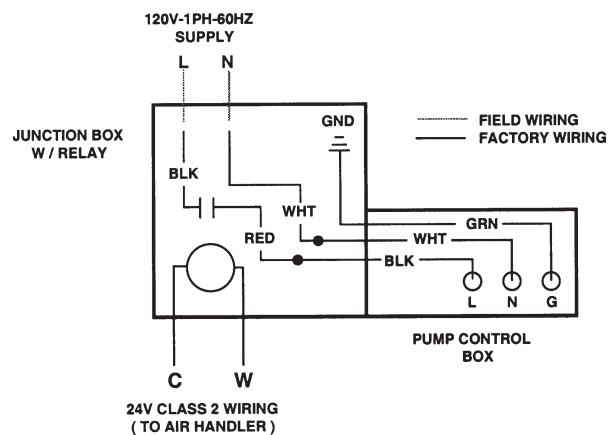

Figure 1

**Check valve:** A check valve is factory installed in the hot water loop to eliminate any thermosyphoning (hot water circulating through the heating coil) while operating in the cooling mode. The check valve is installed within the air handler or as part of the “flow

control module”.

**Air purge valve:** All air handlers and / or “flow control modules” include a large manual air purge valve to facilitate air removal from the heating loop prior to system start - up. When the air handler and water heater are piped according to First Co. instructions, the air in the hot water coil and piping will only need to be removed before initial start - up or after air has gotten into the system because of a plumbing leak or break in a water main. This can be accomplished by using the 2 - step process described under “start - up procedure”.

**Blowerdelayrelay:** FWA-HW,HBXB-HW,HBQB,UC-HW and UCQB series air handlers include a blower delay relay that allows the circulating pump to operate on a call for heat for 20 to 45 seconds **before** the fan motor comes on to deliver warm air quicker when the heating system starts. This relay also keeps the fan motor on for 20 to 45 seconds **after** the thermostat is satisfied in the heating cycle to maximize the efficiency of the heating coil.

**Flue gas safety switch:** All "Q" type air handlers, as well as FWA-xx series air handlers, include a factory installed flue gas safety switch (except 5 ton models). When the blower door is removed for any reason the air handler fan motor will not operate. This is especially important when the water heater is in the same closet as the air handler because products of combustion from the water heater flue pipe could be circulated throughout the duct system if the air handler were allowed to operate without the door in place.

**Water Heater:** Any properly sized gas or oil - fired water heater will work ( even direct vent or powered vent types ). Electric water heaters are not recommended because of their slow recovery rate. Water heater warranties are not affected by this system since no modification of the water heater is necessary. Selection of higher efficiency water heaters will result in even greater savings.

**Boiler:** Most First Co. **Aquatherm**® air handlers and add - on hot water coils are also compatible with boilers and instantaneous water heaters. Please contact the factory for assistance in selecting the proper equipment for these applications. (See Page 10 for wiring diagram of multiple air handlers.)

## ACCESSORIES

**Thermostat:** All "Q" type air handlers will operate with any standard 24 volt heat / cool or heat pump thermostat.

**All other** air handlers require a 24 volt thermostat that energizes the fan motor on a requirement for cooling **and** heating. This is commonly called an "electric heat" thermostat. **CAUTION . . . .** a gas furnace thermostat will **NOT** work with these units because the fan motor will not come on when the thermostat calls for heat.

Normal heat anticipator setting should be 0.3 to 0.4. If a set-back thermostat is used, allow extra time for recovery in the morning.

**Freeze protector:** Kit number 941-1 can be field installed on any **Aquatherm**® air handler or add -on coil and is highly recommended when the air handler or hot water coil is installed in a space that may be subjected to freezing temperatures such as in an attic or crawl space. The sensor attaches to the hot water coil and is wired to R and W in the low voltage circuit. If for any reason the temperature of the hot water coil falls below 38 degrees the sensor will bring on the pump to circulate hot water. This will occur even if the thermostat is in the "off" position.

## EQUIPMENT SIZING

**Condensing unit:** The condensing unit should be sized to meet the calculated heat gain according to an approved heat gain formula.

**Air handler:** Select an air handler with a heating BTUH that exceeds the structure's calculated heat loss and a cooling coil matched to the tonnage size of the outdoor condensing unit.

**Special note . . . .** the actual heating output of the air handler (BTUH) will not be greater than the heating output of the water heater (water heater BTUH input multiplied by it's recovery efficiency) regardless of the listed heating BTUH of the air handler.

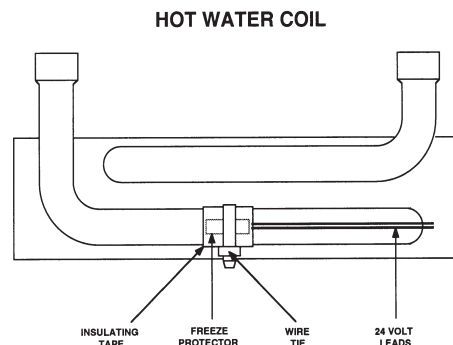

Figure 2

**Water heater:** Add 10 to 20% to the structure's heat loss to obtain the minimum **output** of the required water heater (output = input x recovery efficiency). A minimum 40 gallon high recovery and / or high efficiency gas or oil-fired water heater is recommended. **In addition** to the above formula, the following vol-

ume sizing guide is satisfactory in most parts of the country: (minimum requirements)

1.5 and 2 ton air handlers = minimum 40 gallon

2.5 and 3 ton air handlers = minimum 50 gallon

3.5 and 4 ton air handlers = either two 40 gallon water heaters piped together, one high input (63,000 to 75,000 BTUH) 50 gallon or one 72 to 75 gallon.

5.0 ton air handlers = multiple water heaters or boiler with at least 105,000 BTUH output.

For additional assistance in water heater sizing, contact the factory or a qualified profession engineer.

## INSTALLATION

The installer must adhere strictly to all local and national code requirements pertaining to the installation of this equipment.

Detailed installation instructions are shipped with

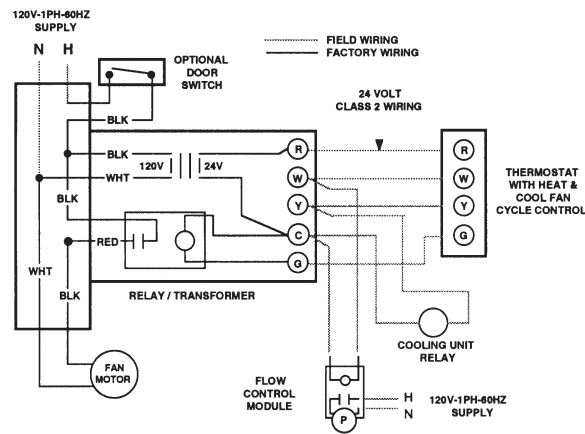

Figure 3

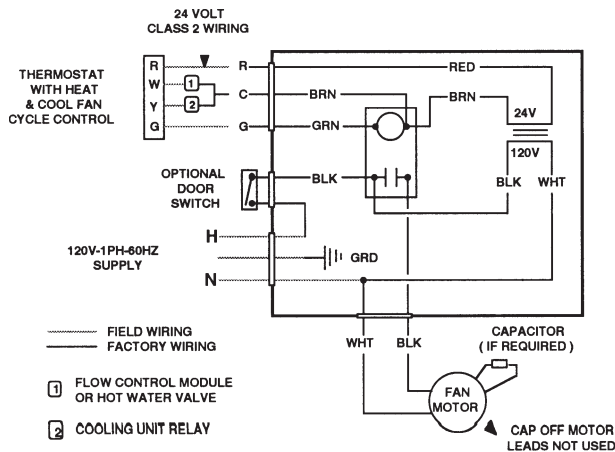

Figure 4

each component of the system and should also be followed in detail.

**Duct work:** The return air duct must have the same free area as the opening provided on the air handler. If there is no ducted return, applicable installation codes may limit the unit to installation only in a single story residence.

**Electrical:** Units are provided with wiring diagrams and nameplate data to provide information required for necessary field wiring. Knockouts are provided in the cabinet for connection of power supply. See "accessories" for thermostat information. All air handlers operate on 115 volt - 1phase - 60 cycle line voltage and 24 volt control.

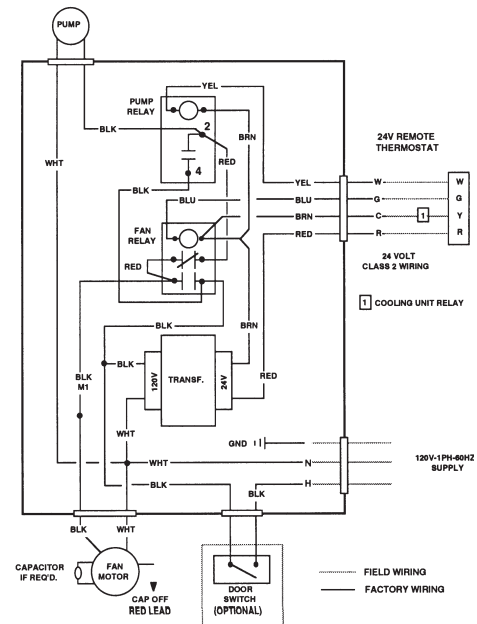
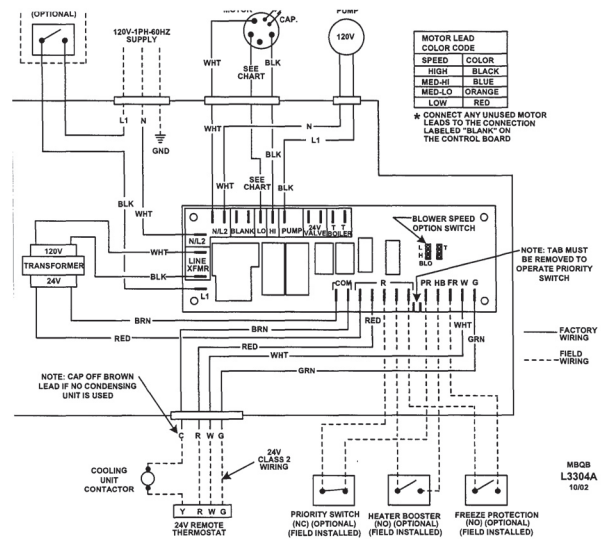

Figure 5



(See figures 3, 4, 5, 14 and 15 for typical wiring diagrams.)

### Water piping:

- 1. Material:** It is recommended that all piping between the water heater and hot water coil be 3/4 inch nominal (7/8 O.D.) copper except the 60HBQB and 60HBXB-HW is 1" nominal (1-1/8" O.D.). Other material approved for potable hot water systems may also be used if approved by local code authorities.
- 2. Solder connections:** All copper joints in the water lines **must** be made with low temperature, non lead solder!
- 3. Insulation:** It is recommended that all piping be adequately insulated to prevent freezing and "freeze protector" ( see "accessories" ) be installed on the hot water coil to prevent freezing when piping is run in a space subjected to freezing temperatures.
- 4. Length:** Piping should not exceed 200 total feet of length. Air handlers should not be installed more than 40 feet above the water heater.
- 5. Shut - off valves:** In addition to the main cold water valve supplying the water heater, it is recommended that one shut - off valve be installed on the hot water supply line to the air handler and one on the return line from the air handler (or hot water coil). These valves will facilitate air purging during start - up ( see "start - up" ) and allow unit isolation for repair.
- 6. Piping connections:** On all cased type air handlers the water inlet or "supply" connection to the hot water coil is the one on the right as you face the the air handler and will be marked accordingly. Air handlers with internally installed circulating pumps **will not circulate water** if piped backwards. Water lines to and from the air handler **must** be connected to the horizontal connection of the "T" fittings in the vertical hot and cold water supply lines at the water heater. (See figure 6).

This insures that any air in the water heater will bypass the heating loop and then be purged each time hot water is used in the dwelling. If this piping procedure is not followed the pump may "air lock" and fail to pump hot water. Any other piping procedure must address the elimination of air in the heating loop. See figures 8 through 9 for approved piping variations. Contact the factory for assistance with alternate piping procedures.

**Air handler:** Holes should **not** be drilled into the air handler or coil cabinets (except through duct flanges) since damage to the coils could result. Multiple air handlers may be installed on one water heater provided the water heater and piping are sized properly. Piping should be similar to that required for individual air handler.

**Flow control module (if required):** The flow control module can be installed anywhere in the hot water loop to or from the air handler (between the water heater and air handler). Modules must be installed with the motor in a horizontal position. Junction box should **not** be installed underneath the pump. Water should flow from the outlet (**hot**) side of the water heater to the air handler and then back to the supply (**cold**) side of the water heater. Arrow on bottom of pump indicates the direction of flow when pump is energized. The module is furnished with a 6 foot cord and plug for convenient connection to a wall outlet. For those areas where local codes require "hard" wiring, discard the cord assembly and wire directly to the connections within the 4 x 4 box using acceptable wiring materials.

**Water heater:** Water heaters should be installed according to the manufacturer's installation instructions. If a "back flow preventer" is required by code, the T & P valve on the water heater may tend to drip water because of pressure build-up in the water

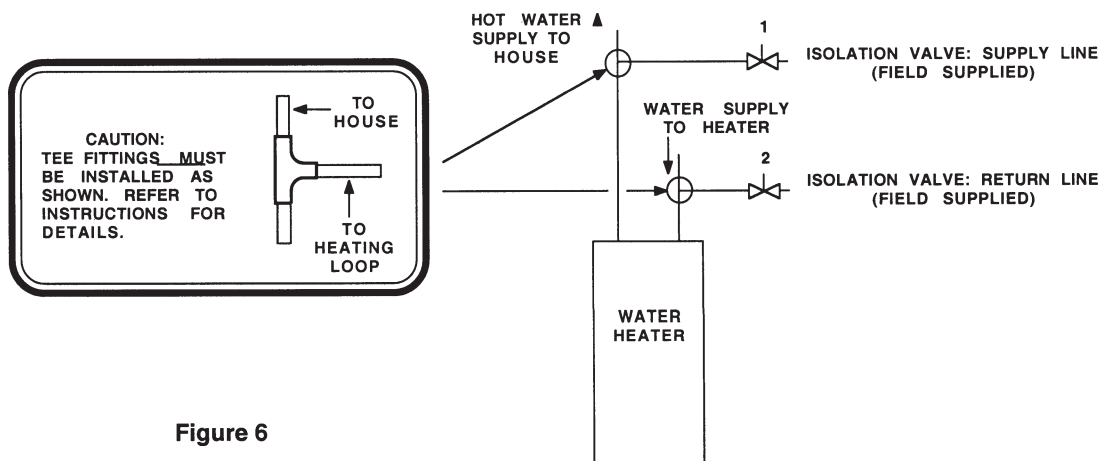

heater. This problem is a direct result of the back flow preventer . . . . not the heating system. An expansion tank may need to be installed to solve this problem. Most water heaters are now labeled with this information.

**Multiple water heaters:** When sizing requirements call for more than one water heater per air handler, water heaters may be connected together according to the water heater manufacturer's instructions. (See figure 10 page 9)

**Anti-scald valve:** A water heater is designed to produce hot water. Hot water represents a serious safety hazard due to the potential of scalding. The temperature of water normally required to provide space heating (135 to 140 degrees) may be hotter than certain codes allow for domestic hot water. An "anti-scald valve" can be installed in the hot water piping that would allow the domestic water to be supplied at a lower temperature than the space heating water. These can be obtained locally and should be installed according to the manufacturer's installation instructions. (See figure 12)

**START - UP PROCEDURE**  
(Heating cycle)

1. Open the main shut - off valve to the water heater and the two shut - off valves to and from the air handler or hot water coil.
2. Fill the water heater. Open a hot water faucet somewhere in the house while filling the water heater in order to vent the air. When the tank is full and all the air is purged, close the faucet.
3. Ignite the water heater according to the manufacturer's instructions and allow it to come up to temperature (about 45 minutes). **DO NOT IGNITE THE WATER HEATER WITHOUT WATER IN THE TANK!**

4. Purge the air handler's hot water coil and lines: The following procedure allows the use of city water pressure to purge the air handler hot water coil and lines even when the air handler is located higher than the water heater. Once the air is completely removed upon start - up, the circulating pump will circulate the required amount of hot water through the heating loop.

**Note:** It may require purging several gallons of water so either have a bucket available or connect a garden hose to the purge valve and route to a drain. Close valve number 2 and open valve number 3 (See figure 7). Next, open the air purge valve located either on the flow control module or inside the air handler. When all the air is purged, close valve number 3 and open valve number 2. When all the air is purged, open both valves and close the air purge valve.

5. On Grundfos pumps, vent the air from the pump chamber by loosening the large screw plug on top of the pump motor until water appears. Then retighten the plug.
6. Switch the room thermostat to "heat" and set it high enough to energize the fan motor and pump. It may be necessary to "feel" the pump to determine if it is operating. If the pump is operating properly and the water temperature in the water heater has reached the set point, the hot water line going into the air handler will begin to get hot. If the pump is running but hot water is not circulating, refer to "troubleshooting".
7. Adjust the water heater thermostat so that the water entering the hot water coil is 135 to 140 degrees with the system energized and operating long enough for all temperatures to stabilize.

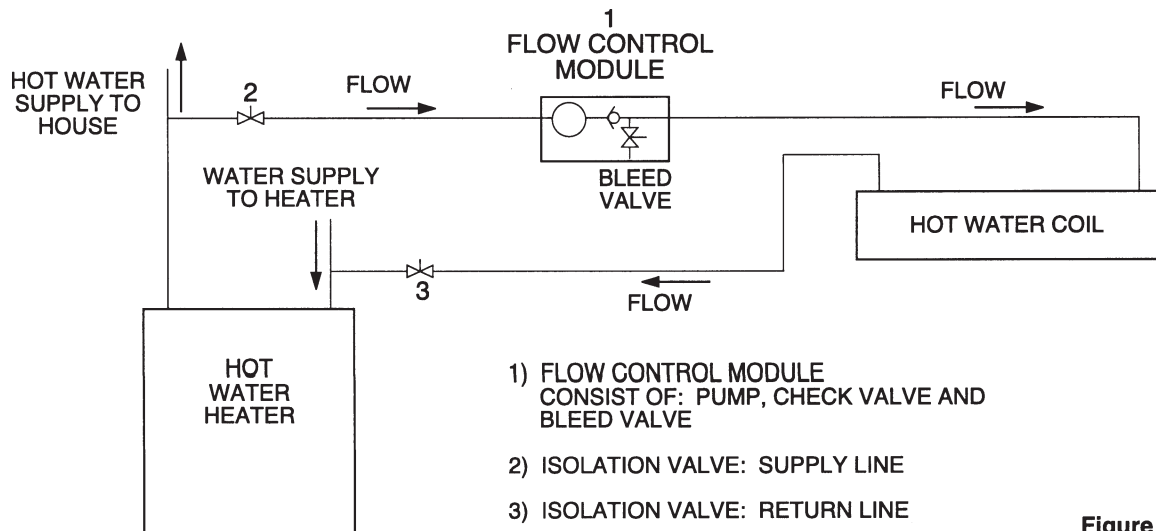

Figure 7

## Conventional Piping Diagram

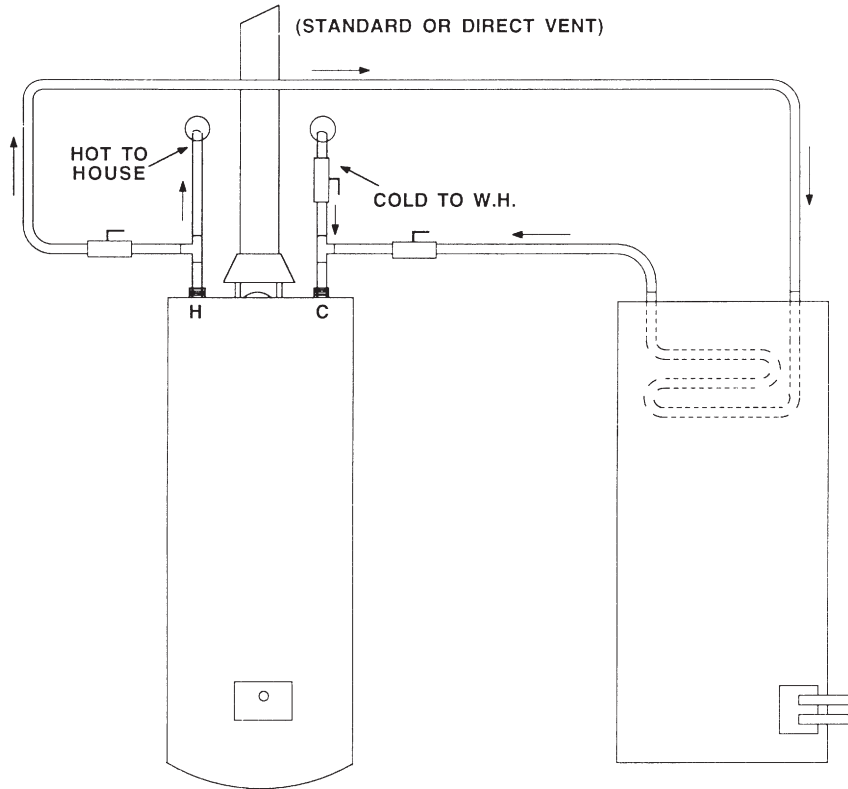
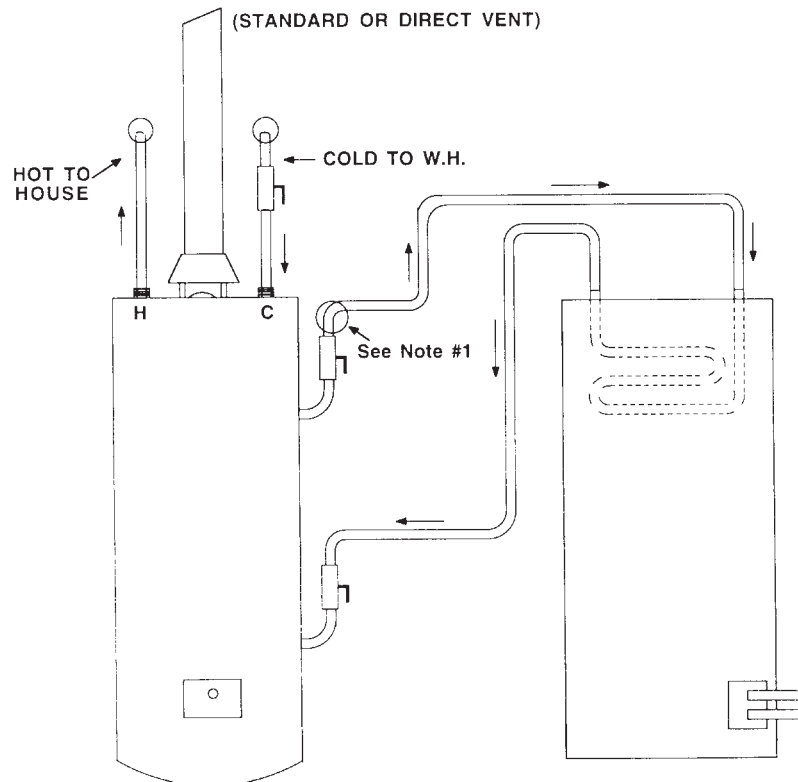

FIGURE 8

## Side Tap (4 Pipe) Water Heater Piping



Notes: 1. Remove and discard spring-loaded check valve from this location before installation

FIGURE 9

**Two Water Heaters With One Air Handler  
(Parallel Connection With Reverse Piping)**

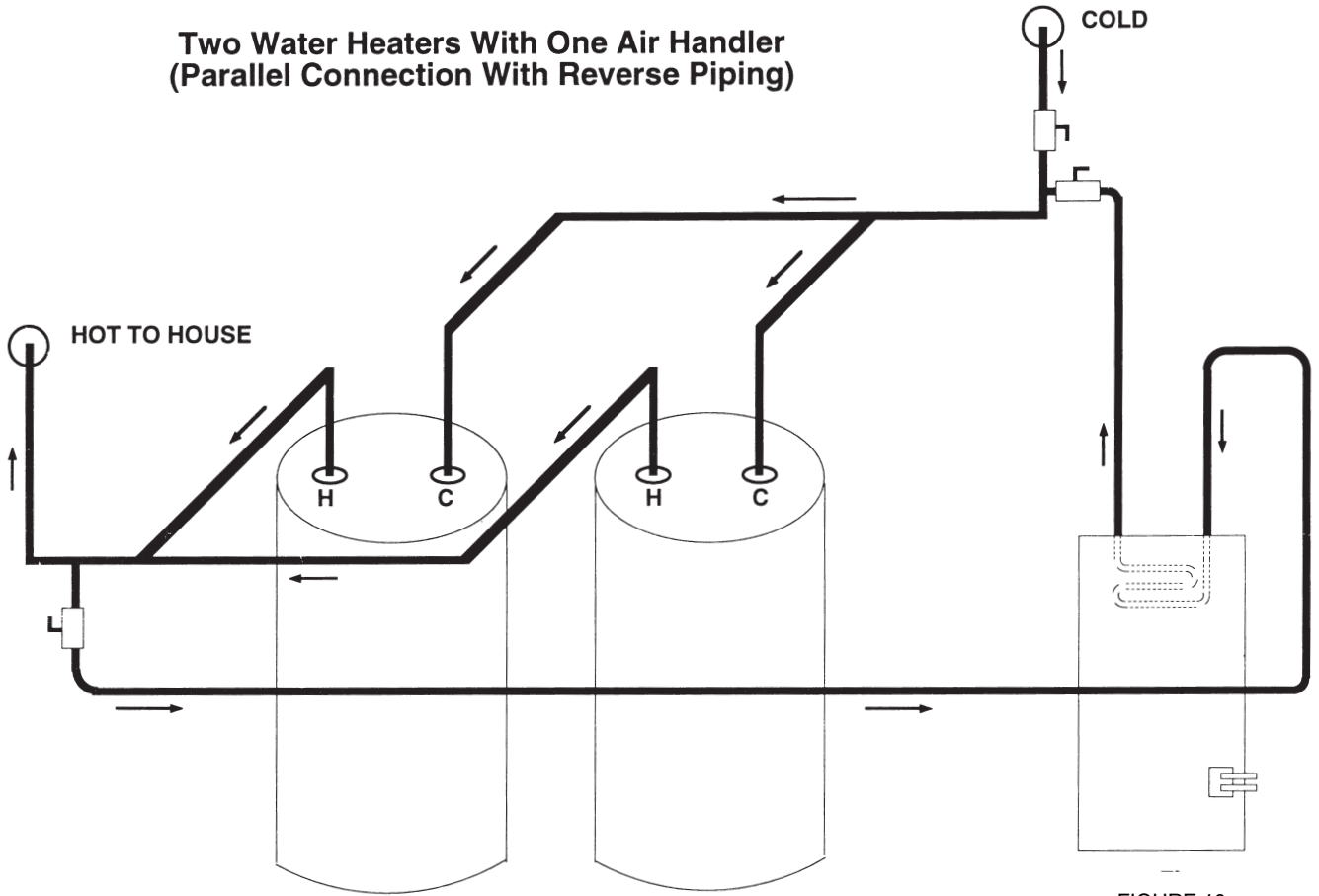

FIGURE 10



## TROUBLESHOOTING

(Most likely problems and cause)

**Important:** For system to operate properly **power should be turned ON and all shut - off valves should be OPEN.**

**Pump does not run:** These pumps may sometimes "stick" due to non - use and fail to start. Before replacing pump:

1. Turn off power. On Grundfos pumps remove large screw plug in end of pump motor and turn shaft several times with a small screwdriver. Replace plug and start system. Pump should start.
2. If pump **has** to be replaced, first shut off all isolation valves between the water heater and air handler and relieve the city water pressure by opening the air purge valve. Then remove the four screws that attach the pump motor to the pump volute rather than un-soldering the entire pump assembly.

**Fan motor runs on cooling but not on heating:**

Thermostat is wrong type (a gas furnace type thermostat will not bring on the fan motor in the heating cycle on certain air handlers). For correct type of thermostat, see "accessories".

**Note:** FWA-HW air handler has a blower delay.

**Pump is noisy:**

Air may still be in the heating loop. Re-purge the system as described under "start - up procedure".

**Water heater T & P valve "weeping":**

This situation usually occurs in those systems located in areas where local codes require the installation of a "backflow preventer" in the cold water supply line to the water heater. This situation is caused by the expansion of the water when heated. An expansion tank may be required to solve this problem. Contact local plumbing authorities for assistance.

**Insufficient or no heat:**

1. Air still in heating loop. Re-purge system.
2. Inlet and outlet piping connections at the air handler may be piped backwards. (See "Piping connections").

3. Water heater thermostat not turned up high enough.
4. Water heater thermostat not calibrated properly.
5. Restricted or improperly installed dip tube in water heater.
6. Restriction somewhere in heating loop. Confirm that no other check valves or devices have been installed in the heating loop except as supplied by First Co.  
**Note:** Some water heaters come with a normally closed spring-loaded check valve factory installed on one of the space heating connections. Since the circulating pump in the **Aquatherm**® system may not be able to open this valve in addition to the **Aquatherm**® check valve, this valve should be removed before installation.
7. Air handler or hot water coil not large enough.
8. Water heater not large enough.

**Hot water circulates through hot water coil during cooling cycle:**

1. Check valve may be stuck open allowing "thermosyphoning" (circulation) of hot water. This occurs when the hot water pipes are not capped-off during installation, allowing foreign debris such as solder, insulation, and other building materials to enter the piping. If not completely purged from the system, this "debris" can lodge under the check valve seat and allow hot water to flow through the hot water coil even in the summer. To solve this problem, flush the heating loop several times as indicated in the "start-up procedure" on Page 7.

note: Check valve in models made after year 1999 are located in the pump itself.

## CONCLUSION

Always leave the appropriate literature and / or manual with the homeowner and whenever possible take the time to explain the operation and advantages of the system.

**All technical specifications subject to change without notice.**

**Catalog No. IAM1010** (Replaces IAM309)