

**NOW AVAILABLE WITH
"AUTOSPEED 24V" CONTROL**



Product Specifications

**MB Series
MBE Series
MB-HW Series**

**Vertical / Horizontal
Direct Drive
Hydronic Fan Coils
300 - 2100 CFM**

NEW OPTION AVAILABLE: "AUTOSPEED 24V" CONTROL PACKAGE *(With 24V, Automatic 3-speed fan selection)*

MB Series
(2-pipe, cooling and heating)
(replaces the MH Series)



MB-HW Series
(4-pipe, cooling and heating)
(replaces the MH-HW Series)



MBE Series
(2-pipe, cooling with electric heat)
(replaces the MHE Series)



Table of contents

<u>DESCRIPTION</u>	<u>PAGE</u>
General Construction Features.....	3
Model Number Nomenclature.....	3
MB Series - Cooling / Heating (2-pipe)	4
MB-HW Series - Cooling / Heating (4-pipe)	5
MBE Series - Cooling / Electric Heat	6
Cooling Capacities (all models)	7
Valves	7

3-WAY AIRFLOW (MB, MBE, MB-HW)

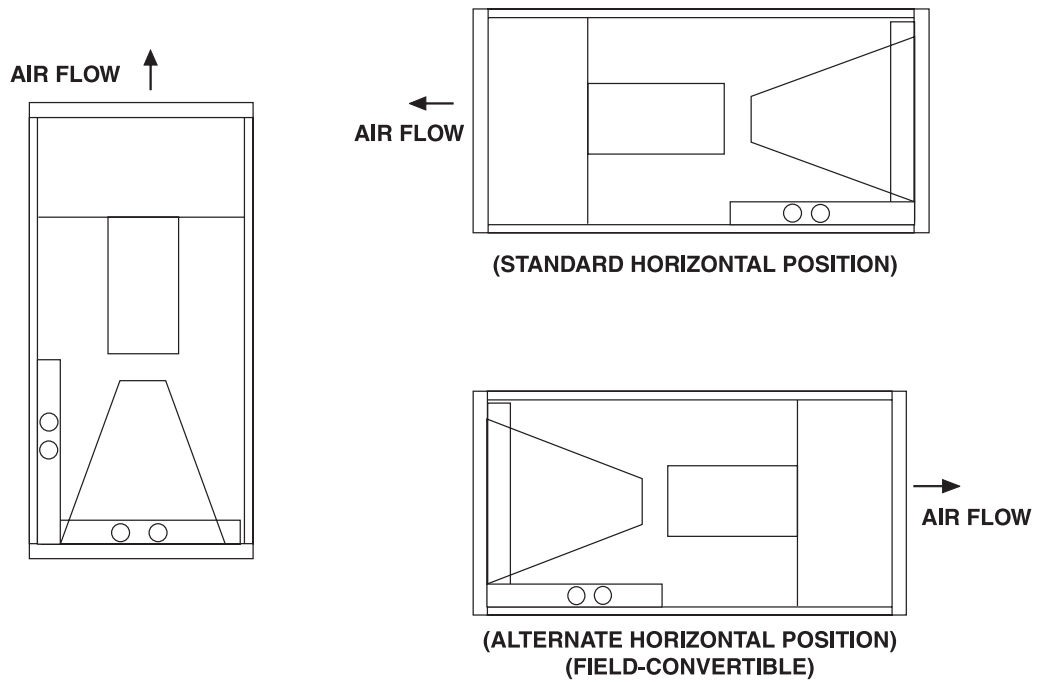

General Construction Features

Basic Unit

All models are manufactured with heavy gauge galvanized steel to resist corrosion.

Each cabinet is fully insulated.

Coil connections are stubbed out the cabinet for easier installation.

Coils

Coils have 3/8 inch copper tubing expanded to high efficiency aluminum fins. Manual air vents are provided and all coils are pressure tested to 350 psig.

Drain Pans

All fan coils can be installed vertically or horizontally (right-to-left airflow) with no modification. Horizontal drain pans can be repositioned within the cabinet to allow horizontal installation with left-to-right airflow. Each drain pan is coated with a "mastic" material to reduce corrosion.

Threaded primary and secondary drain connections are also provided.

Motors

Standard motors are PSC type with internal thermal overload protection and are mounted with rubber isolation bushings.

Blower wheels are centrifugal, forward curved, and dynamically balanced.

Filters

One inch throw away filters are factory installed.

Agency Listing

All standard models are U.L. Listed.

MB Series

The MB Series 2-pipe fan coil comes with a 4 row cooling / heating coil and a 120V multi-speed motor. No controls are furnished.

MBE Series (240V)

The MBE Series 2-pipe fan coil comes with a 4 row cooling coil, 240V multi-speed motor, 240/24 transformer, and up to 25kW of factory installed electric heat. Models with more than 10kW also include a circuit breaker for branch circuit protection. Control voltage is 24V.

MBE Series (277V)

This fan coil comes with a 4 row cooling coil, 277V multi-speed motor, and up to 10kW of factory installed electric heat. All models are U.L. Listed.

MB-HW Series

The MB-HW Series 4-pipe fan coil includes a 4 row cooling coil, a 2, 3, or 4 row heating coil installed in the reheat position, and a 120V multi-speed motor. No controls are furnished.

Additional Features

Optional "Autospeed 24V" control: (see P.8)

The MB and MB-HW models are available with an optional 24V 3-speed control board and a 24V 3-speed digital wall thermostat. This option, called the "Autospeed 24V", provides maximum comfort and efficiency by automatically selecting the appropriate High, Medium, or Low fan speed, depending on room temperature and thermostat temperature setting.

Model Number Nomenclature

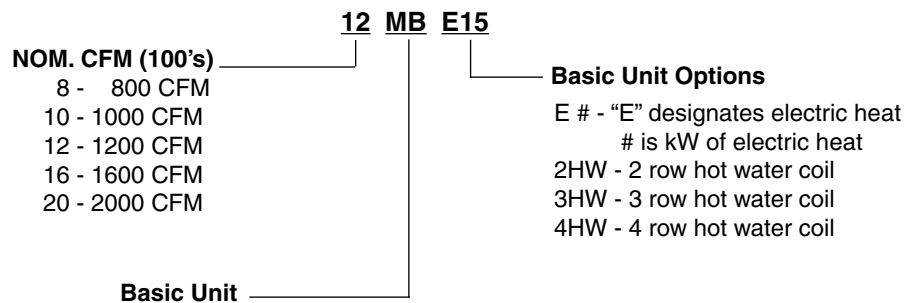

In keeping with its policy of continuous progress and product improvement, First Operations reserves the right to make changes without notice. Maintenance for all First Co. products is available under "Product Maintenance" at www.firstco.com.

MB Series

Cooling / Heating (2-pipe)

PHYSICAL DIMENSIONS											
UNIT MODEL	A	B	C	D	E	F	G	H	COIL CONNECTIONS	FILTER SIZE	SHIP WT. (LBS)
8MB	40	20	20	18-1/2	16	2	18	16	7/8 SWEAT	18 X 20 X 1	115
12MB	42	23	20	21-1/2	16	2	18	17	7/8 SWEAT	20 X 22 X 1	120
16/20MB	48	28	21-1/4	26-1/4	17-1/4	2	19-1/4	18	1-1/8 SWEAT	20 X 25 X 1	210

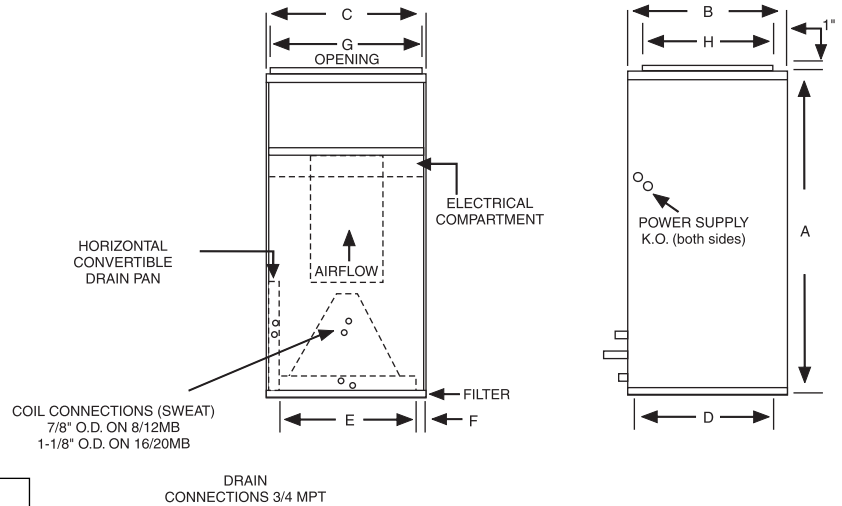

NOTE: See Page 7 for cooling capacities and hand/motorized valves

In keeping with its policy of continuous progress and product improvement, First Operations reserves the right to make changes without notice. Maintenance for all First Co. products is available under "Product Maintenance" at www.firstco.com.

HEATING DATA - 180°F EWT, 70°F EAT						
UNIT MODEL	CFM	GPM	P.D. (FT. WTR.)	HEAT BTUH (1000)	LVG AIR °F	LVG WTR °F
8MB	800	3.0	2.5	57.7	137	132
		4.5	5.5	62.2	142	142
		6.0	9.5	65.0	145	148
	600	3.0	2.5	47.8	144	138
		4.5	5.5	51.0	149	147
		6.0	9.5	53.1	152	152
12MB	1200	4.0	2.4	83.9	135	128
		6.0	4.8	90.9	140	140
		8.0	7.9	95.2	144	146
	1000	4.0	2.4	74.7	139	133
		6.0	4.8	80.3	144	143
		8.0	7.9	83.8	148	149
16MB	1600	6.0	3.3	118.7	138	131
		8.0	5.4	124.7	142	139
		10.0	7.9	129.5	145	144
	1400	6.0	3.3	108.3	142	134
		8.0	5.4	114.0	145	142
		10.0	7.9	118.1	148	146
20MB	2000	7.0	4.3	141.6	136	126
		10.0	7.9	151.3	140	140
		13.0	12.5	157.5	143	146
	1600	7.0	4.3	121.7	140	135
		10.0	7.9	129.5	145	144
		13.0	12.5	134.4	148	149

Features:

1. 4 row cooling / heating coil
2. 120V multi-speed motor
3. Vertical / Horizontal drain pan (right-to-left and left-to right airflow)
4. Manual air vent
5. Throw away filter

BLOWER DATA									
UNIT MODEL	NOM. COOL TONS	MOTOR HP-AMP (120V)	MOTOR SPEED	CFM vs. EXTERNAL STATIC PRESSURE					
				0.05	0.10	0.20	0.30	0.40	0.50
8MB	2	1/5-3.0	High	920	890	825	750	680	580
			Med-Hi	750	730	680	610	540	450
			Med-Low	555	530	480	420	330	---
			Low	350	310	240	170	100	---
12MB	3	1/3-6.0	High	1220	1185	1120	1070	1015	960
			Med-Hi	1085	1060	1010	960	910	865
			Med-Low	935	915	875	830	775	700
			Low	750	730	695	650	605	550
16MB	4	1/2-8.0	High	1730	1690	1620	1540	1450	1350
			Med	1580	1550	1490	1430	1360	1270
			Low	1360	1340	1310	1270	1210	1100
			20MB	5	3/4-10.5	High	2030	2000	1950
Med	1630	1615				1580	1540	1490	1440
Low	1280	1270				1240	1210	1180	1140

NOTE: Discharge air temperature must not exceed 150 degrees.



MB-HW Series

Cooling / Heating

(4-pipe)

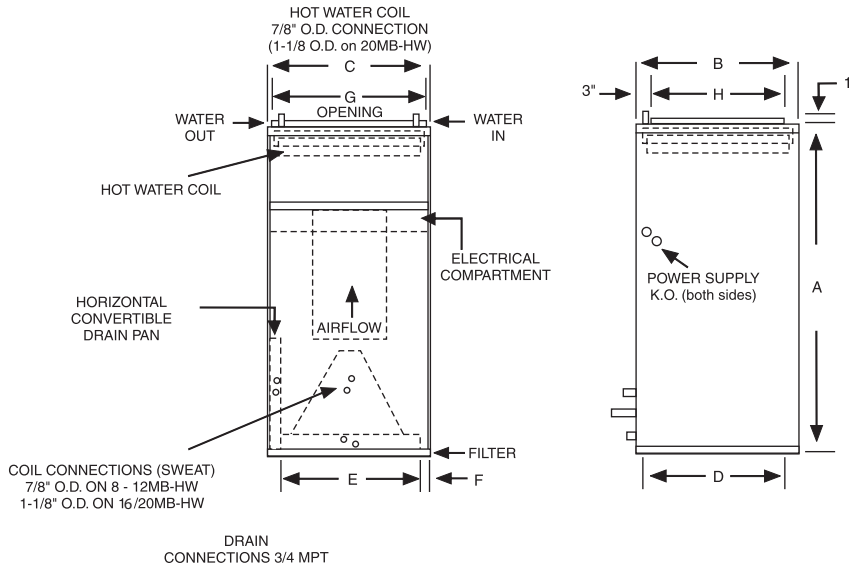

Features:

1. Separate cooling and heating coils (4 row cooling coil)
2. 120V multi-speed motor
3. Vertical / Horizontal drain pan (right-to-left and left-to-right airflow)
4. Manual air vent
5. Throw away filter

HOT WATER COIL PERFORMANCE DATA						
UNIT MODEL	CFM	GPM	P.D. (FT. WTR.)	HEATING BTUH (1000) AT ENTERING WATER TEMPERATURE (1)		
				120°F	140°F	180°F
8MB-2HW	800	1	0.13	13.0	18.2	28.6
		2	0.51	17.4	24.3	38.2
		3	1.13	18.9	26.5	41.7
	600	1	0.13	11.3	15.8	24.8
		2	0.51	14.9	20.8	32.7
		3	1.13	16.1	22.5	35.4
8MB-3HW	800	1	0.22	16.6	23.3	36.5
		2	0.83	22.2	31.1	48.8
		3	1.83	24.2	33.9	53.2
	600	1	0.22	14.2	19.9	31.2
		2	0.83	18.7	26.2	41.4
		3	1.83	20.2	28.3	44.5
10MB-3HW	1000	2	1.04	26.3	36.8	57.8
		4	3.64	30.7	43.0	67.6
		6	7.55	32.8	45.9	72.2
	800	2	1.04	23.1	32.3	50.7
		4	3.64	26.7	37.4	58.8
		6	7.55	28.4	39.8	62.5
12MB-3HW	1300	2	1.10	30.2	42.3	66.5
		4	3.64	35.9	50.3	78.9
		6	7.55	38.6	54.0	84.9
	1100	2	1.10	27.9	39.0	61.3
		4	3.64	32.7	45.7	71.8
		6	7.55	34.9	48.9	76.8
16MB-4HW	1700	4	1.40	50.5	70.7	111.2
		6	2.89	55.0	77.0	121.0
		8	4.83	57.9	81.0	127.4
	1500	4	1.40	46.7	65.3	102.6
		6	2.89	50.6	70.9	111.4
		8	4.83	53.2	74.4	116.9
20MB-4HW	2100	5	1.86	62.4	87.4	137.4
		7	3.33	67.0	93.9	147.5
		9	5.15	70.2	98.3	154.5
	1800	5	1.86	56.6	79.3	124.6
		7	3.33	60.6	84.8	133.3
		9	5.15	63.3	88.6	139.3

PHYSICAL DIMENSIONS										
UNIT MODEL	A	B	C	D	E	F	G	H	FILTER SIZE	SHIP WT. (LBS)
8MB-HW	40	20	20	18-1/2	16	2	18	16	18 X 20 X 1	120
10/12MB-HW	42	23	20	21-1/2	16	2	18	19	20 X 22 X 1	135
16MB-HW	48	28	21-1/4	26-1/4	17-1/4	2	18	24	20 X 25 X 1	210
20MB-HW	52	28	25-1/4	26-1/2	21-1/4	2	22	24	14 X 24 X 1 (2 required)	260

BLOWER DATA										
UNIT MODEL	NOM. COOL TONS	MOTOR HP-AMP (120V)	MOTOR SPEED	CFM vs. EXTERNAL STATIC PRESSURE						
				0.05	0.10	0.20	0.30	0.40	0.50	
8MB-HW	2	1/5-4.5	High	950	920	855	790	720	645	
			Med	860	835	785	720	650	580	
			Low	780	755	705	650	590	510	
10MB-HW	2.5	1/5-4.5	High	1120	1095	1045	995	940	880	
			Med	850	840	810	780	740	690	
			Low	680	670	655	625	585	510	
12MB-HW	3	1/2-8.0	High	1340	1310	1250	1190	1120	1050	
			Med	1290	1260	1200	1140	1080	1000	
			Low	1200	1170	1120	1070	1010	940	
16MB-HW	4	3/4-10.5	High	1810	1780	1760	1660	1590	1530	
			Med	1570	1550	1510	1460	1400	1340	
			Low	1280	1260	1220	1180	1130	1050	
20MB-HW	5	1-10.4	High	2160	2125	2055	1980	1895	1810	
			Med	1865	1840	1785	1710	1620	1525	
			Low	1560	1540	1490	1435	1365	1260	

NOTE: See Page 7 for cooling capacities and accessories

In keeping with its policy of continuous progress and product improvement, First Operations reserves the right to make changes without notice. Maintenance for all First Co. products is available under "Product Maintenance" at www.firstco.com.

(1) Contact factory for capacities at other conditions.

MBE Series

Cooling / Electric Heat

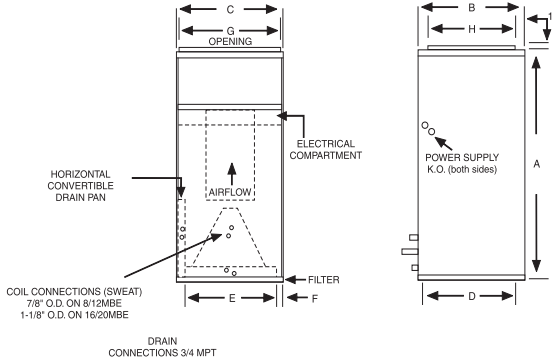

PHYSICAL DIMENSIONS											
UNIT MODEL	A	B	C	D	E	F	G	H	COIL CONNECTIONS	FILTER SIZE	SHIP WT. (LBS)
8MBE	40	20	20	18-1/2	16	2	18	16	7/8 SWEAT	18 X 20 X 1	115
12MBE	42	23	20	21-1/2	16	2	18	17	7/8 SWEAT	20 X 22 X 1	120
16/20MBE	48	28	21-1/4	26-1/4	17-1/4	2	19-1/4	18	1-1/8 SWEAT	20 X 25 X 1	210

BLOWER DATA (240V)											
UNIT MODEL	NOM. COOL TONS	MOTOR HP-AMP (240V)	MOTOR SPEED	DUTY	CFM vs. EXTERNAL STATIC PRESSURE						
					0.05	0.10	0.15	0.20	0.30	0.40	0.50
8MBE	2	1/6-2.0	HIGH LOW	COOL HEAT	900	880	860	830	790	700	600
					740	710	690	660	630	570	490
12MBE	3	1/3-2.5	HIGH LOW	COOL HEAT	1410	1380	1340	1310	1270	1190	1060
					1170	1150	1130	1100	1080	1030	970
16MBE	4	1/2-3.5	HIGH MED LOW	COOL COOL HEAT	1760	1730	1680	1640	1580	1480	1360
					1490	1460	1430	1400	1370	1300	1210
20MBE	5	3/4-5.0	HIGH LOW	COOL HEAT	2130	2110	2090	2060	2025	1930	1820
					1690	1680	1660	1640	1620	1580	1540

NOTE:
16MBE is factory wired on high speed for cooling.

ELECTRICAL DATA (240 / 208V)										
UNIT MODEL	ELECTRIC HEAT CAPACITY				TOTAL AMPS		MIN. CIR. AMPACITY		MAX. FUSE OR HACR BREAKER	
	kW		BTUH							
	240V	208V	240V	208V	240V	208V	240V	208V	240V	208V
8MBE	3	2.3	10,200	7,700	14	13	18	16	20	20
	4	3	13,600	10,200	19	16	23	20	25	20
	5	3.8	17,000	13,000	23	20	28	25	30	25
	6	4.5	20,500	15,400	27	24	36	29	40	30
	8	6	27,300	20,500	35	31	46	38	50	40
12MBE	5	3.8	17,000	13,000	24	21	30	26	30	30
	8	6	27,300	20,500	36	32	46	40	50	40
	10	7.5	34,100	25,600	45	39	56	49	60	50
	(1) 15	11.3	51,100	38,500	45	39	56	49	60	50
					21	18	26	23	30	25
16MBE	5	3.8	17,000	13,000	25	22	30	27	30	30
	8	6	27,300	20,500	37	33	47	40	50	40
	10	7.5	34,100	25,600	46	40	57	50	60	50
	(1) 15	11.3	51,100	38,500	46	40	57	50	60	50
	(1) 20	15	68,200	51,100	21	18	27	23	30	25
					46	40	57	50	60	50
					42	36	53	46	60	50
	(1) 25	18.75	85,250	63,900	46	40	57	50	60	50
					42	36	53	46	60	50
20MBE	5	3.8	17,000	13,000	27	24	34	30	35	30
	8	6	27,300	20,500	40	35	49	44	50	45
	10	7.5	31,100	25,600	48	42	60	53	60	60
	(1) 15	11.3	51,100	38,500	48	42	60	53	60	60
	(1) 20	15	68,200	51,100	21	18	27	23	30	25
					48	42	60	53	60	60
					42	36	53	46	60	50
	(1) 25	18.75	85,300	63,900	48	42	60	53	60	60
					42	36	53	46	60	50

(1) 15kW and 20kW models require 2 supply circuits.
25kW models require 3 supply circuits.

NOTES:
Units suitable for installation with 0" clearance to combustible material.

NOTE: See Page 7 for cooling capacities and accessories

In keeping with its policy of continuous progress and product improvement, First Operations reserves the right to make changes without notice. Maintenance for all First Co. products is available under "Product Maintenance" at www.firstco.com.

- Features:**
1. Factory installed electric heat
 2. 4 row cooling coil
 3. 208/240V motor
 4. 240/24V transformer
 5. Circuit breaker disconnect (above 10kW) (Except 277V)
 6. Manual air vent
 7. Throw away filter
 8. Vertical / horizontal drain pan (right-to-left and left-to-right airflow)
 9. 277 V models available (10kW max) (See below)

ELECTRICAL DATA (277V)						
UNIT MODEL	ELECTRIC HEAT CAPACITY			TOTAL AMPS	MIN. CIR. AMPACITY	MAX. FUSE OR HACR BREAKER
	kW	HP	BTUH			
8MBE	0	-	-	1.2	-	-
	3	1/6	10,200	12	15	15
	5		17,000	20	24	25
	6		20,500	23	29	30
	8		27,300	30	38	40
	10		34,100	38	47	50
12MBE	0	-	-	2.4	-	-
	5	1/3	17,000	21	26	30
	8		27,300	32	40	40
	10		34,100	39	49	50
16MBE	0	-	-	3.0	-	-
	5	1/2	17,000	21	27	30
	8		27,300	32	40	40
	10		34,100	39	49	50
20MBE	0	-	-	4.0	-	-
	5	3/4	17,000	22	28	30
	8		27,300	33	40	40
	10		34,100	40	50	50

CHILLED WATER COOLING CAPACITY - 4 ROW (MB, MB-HW, MBE SERIES)																
UNIT MODEL	CFM	GPM	P.D. (FT. WTR.)	45°F ENTERING WATER						42°F ENTERING WATER						
				80°F DB/67°F WB ENT. AIR			75°F DB/63°F WB ENT. AIR			80°F DB/67°F WB ENT. AIR			75°F DB/63°F WB ENT. AIR			
				TOTAL MBH	SENS. MBH	TEMP. RISE	TOTAL MBH	SENS. MBH	TEMP. RISE	TOTAL MBH	SENS. MBH	TEMP. RISE	TOTAL MBH	SENS. MBH	TEMP. RISE	
8MB	600	3.0	2.5	19.0	13.8	12.7	14.5	12.1	9.7	20.7	14.4	13.8	15.8	12.6	10.5	
		4.5	5.5	22.4	15.1	9.9	17.1	13.1	7.6	24.4	15.9	10.8	18.6	13.7	8.3	
		6.0	9.5	24.4	15.9	8.2	18.7	13.7	6.2	26.6	16.8	8.9	20.3	14.4	6.8	
	800	3.5	3.4	23.1	17.3	13.2	17.6	15.2	10.1	25.2	18.1	14.4	19.2	15.8	11.0	
		5.0	6.7	26.9	18.7	10.7	20.5	16.3	8.2	29.3	19.6	11.7	22.4	17.1	8.9	
		6.5	11.0	29.2	19.6	9.0	22.3	17.0	6.9	31.8	20.6	9.8	24.3	17.8	7.5	
10/12MB	1000	4.0	2.4	28.3	21.6	14.1	21.6	19.0	10.8	30.8	22.5	15.4	23.6	19.7	11.8	
		6.0	4.8	33.9	23.7	11.3	25.9	20.6	8.6	36.9	24.8	12.3	28.2	21.6	9.4	
		8.0	7.9	37.3	25.0	9.3	28.5	21.7	7.1	40.6	26.3	10.2	31.0	22.7	7.8	
	1200	5.0	3.5	33.7	25.5	13.5	25.8	22.4	10.3	36.8	26.6	14.7	28.1	23.3	11.3	
		6.5	5.5	38.0	27.1	11.7	29.1	23.7	8.9	41.5	28.4	12.8	21.7	24.7	9.7	
		8.0	7.9	41.0	28.2	10.3	31.3	24.6	7.8	44.7	29.6	11.2	34.1	25.7	8.5	
16MB	1400	4.5	2.0	36.2	29.2	16.1	27.7	25.8	12.3	39.5	30.3	17.6	30.1	26.7	13.4	
		6.0	3.3	42.4	31.4	14.1	32.4	27.6	10.8	46.2	32.8	15.4	35.3	28.7	11.8	
		7.5	4.8	46.9	33.1	12.5	35.8	28.9	9.6	51.1	34.7	13.6	39.0	30.2	10.4	
	1600	6.0	3.3	44.2	34.1	14.7	33.8	30.0	11.3	48.2	35.5	16.1	36.8	31.2	12.3	
		8.0	5.4	51.0	36.6	12.7	38.9	32.0	9.7	55.5	38.3	13.9	42.4	33.4	10.6	
		10.0	7.9	55.7	38.4	11.1	42.5	33.4	8.5	60.7	40.3	12.1	46.3	34.9	9.3	
20MB	1600	6.5	3.8	46.1	34.8	14.2	35.2	30.6	10.8	50.3	36.3	15.5	38.4	31.8	11.8	
		8.5	6.0	52.3	37.1	12.3	39.9	32.4	9.4	57.0	38.8	13.4	43.5	33.8	10.2	
		10.5	8.6	56.6	38.7	10.8	43.2	33.7	8.2	61.7	40.7	11.8	47.1	35.2	9.0	
	2000	7.0	4.3	52.4	40.9	15.0	40.0	36.1	11.4	57.1	42.6	16.3	43.6	37.4	12.5	
		10.0	7.9	61.7	44.3	12.3	47.1	38.8	9.4	67.3	46.4	13.5	51.4	40.5	10.3	
		13.0	12.5	67.5	46.5	10.4	51.6	40.5	7.9	73.6	48.8	11.3	56.2	42.4	8.6	

NOTE:

1. All cooling coils have four rows.
2. Contact factory for capacities at other conditions.

ACCESSORIES: (field installed) MB, MB-HW, MBE Series	
Power Heads: (two power heads required for 4-pipe) - For all units	
E50131180 E50132180 E50137180 E50138180	24V 110V/50Hz - 120V/60 Hz 277V 220V/50 Hz – 230V/60 Hz
Separate Valve Bodies: (order power heads separately)	
E421317 E431317 E421417 E431417	3/4" 2-way - For (P)HYB, 8-12MB/MBE/MB-HW (and 8-16MB-HW htg. coil) 3/4" 3-way - For (P)HYB, 8-12MB/MBE/MB-HW (and 8-16MB-HW htg. coil) 1" 2-way - For 16 - 20MB/MBE/MB-HW (and 20MB-HW htg. coil) 1" 3-way - For 16 - 20MB/MBE/MB-HW (and 20MB-HW htg. coil)
Hand Valves: (Combination balance / shut-off) (2 usually req'd per coil)	
CP90 CP905	3/4" For 8-12MB/MBE/MB-HW (8-16MB-HW Htg. coil) 1" For 16-20MB/MBE/MB-HW (16 and 20MB-HW Htg. coil)
Relay - Transformer	
310-E301	120 / 24V for ALL 120V motors

NOTE:

1. Power head leads are 18".



CP905

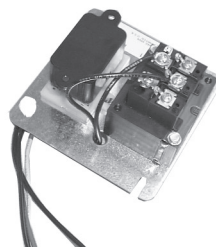

310-E301

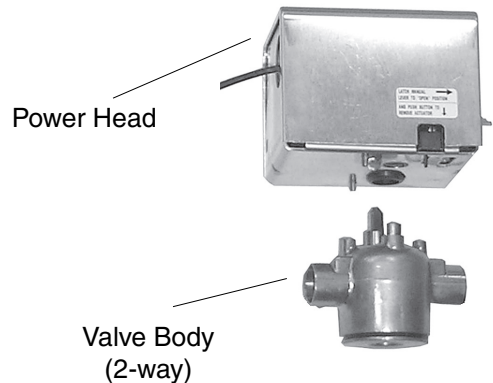

Power Head

Valve Body (2-way)

The "Autospeed 24V™" Thermostats (Part #'s T200/T201)

AUTOMATIC
FAN SPEED CONTROL

Accurate, Efficient, and Quiet Fan Coil Operation

The new **Autospeed 24V™** thermostat (part's # **T200** and **T201**) provides 24V AC single stage temperature control of 2 pipe and 4 pipe fan coil applications. The **T200/T201** thermostat offers maximum comfort and efficiency by *automatically selecting the appropriate High, Medium, or Low fan speed*, depending on room temperature and thermostat temperature setting. This automatic fan speed control not only brings the room temperature to the desired set point quickly, it maintains the room temperature with the most efficient fan speed selection. Once the desired room temperature is achieved the fan coil operates on low speed for extremely quiet operation. The fan coil **control board** (which is factory installed in all CW units) is a circuit board that provides control of a 3-speed line voltage fan motor. The **control board** allows the thermostat to control the fan motor even though, by itself, the thermostat does not have the amperage capability nor the voltage rating capability to control the fan motor.



(T200 shown with wall plate)

T200/T201 Thermostat Features

- Compatible with 2 pipe and 4 pipe fan coils: Series HBC/PHBC/RHBC/CHBC, MB/MB-HW, HYB/PHYB, and CW/CH-HW/CWE
- Cycle fan or continuous fan operation
- **T200**-Manual Heat / Cool changeover switch
- **T201**-Automatic Heat / Cool changeover switch
- Large LED digital display
- Allows less expensive 24V control wiring from the fan coil to the thermostat, rather than larger, more expensive line voltage wiring.
- 3-speed fan operation, with speed indicator lights
- Fan speed determination:
 - If room temperature is 4 degrees (F.) off thermostat set point, fan will operate on High speed.
 - If 3 degrees off set point, fan will operate on Medium speed.
 - If within 2 degrees of set point, fan will operate on Low speed.
- One or 3 hour Auto override - Fan speed defaults to "Auto" mode after 1 hour if the user manually changes it to a particular fan speed.
- Temperature set range: 64-88 degrees F.
- Adjustable high and low temperature set points
- Selectable Fahrenheit / Centigrade display
- Power switch turns system off/on
- Requires 7-wire 24V thermostat wire
- No batteries required
- Set points are permanently retained in memory in case of power interruption
- Simple operation
- Mercury Free
- Wall plate included

DISPLAY CODES		
DISPLAY	STEADY	FLASHING
P1	Auto fan timer - 1 hour (default)	Auto fan timer - 3 hour
P2	Continuous fan (default)	Cycled fan
P3	°F (default)	°C
P4	Cycled fan standard	Cycled fan overdrive (default)
P5	Low temp limit 64 °F (default)	Low temp limit 67 °F
P6	Hi temp limit 88 °F (default)	Hi temp limit 84 °F