

SPX SERIES

PACKAGED AIR CONDITIONING/HEAT PUMP UNITS INSTALLATION, OPERATION AND MAINTENANCE INSTRUCTIONS

****WARNING TO INSTALLER, SERVICE PERSONNEL AND OWNER****

Altering the product or replacing parts with non authorized factory parts voids all warranty or implied warranty and may result in adverse operational performance and/or a possible hazardous safety condition to service personnel and occupants. Company employees and/or contractors are not authorized to waive this warning. Current **Maintenance Program** is available at www.firstco.com under "Product Information".

GENERAL

These instructions give information relative to the SPX unit only. Refer to Wall Sleeve and Grille installation instructions for those components. The manufacturer assumes no responsibility for equipment installed in violation of any code requirements. For other related equipment refer to the proper instructions.

The SPX is shipped in one package, completely assembled. Material in this shipment has been inspected at the factory and released to the transportation agency in good condition. When received, a visual inspection of all cartons should be made immediately. Any evidence of rough handling or apparent damage should be noted on the delivery receipt and the material inspected in the presence of the carrier's representative. If damage is found a claim should be filed against the carrier immediately.

HW Units - Note: State of MA.-248 CMR code of the state of MA. requires a pump timer (60 seconds on every 6 hours). See diagram.

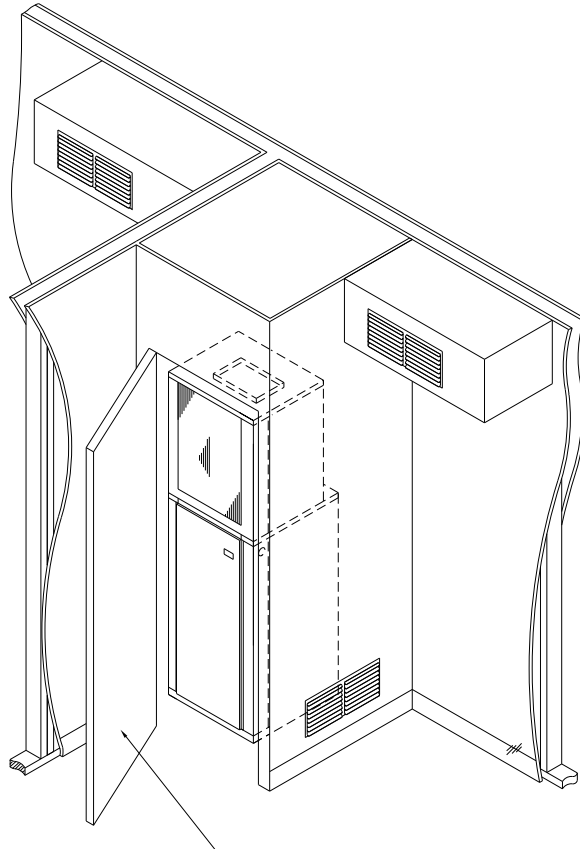

Figure 1 - Typical Suite Installation

******* WARNING *******

Unit must not be operated during building construction due to excessive airborne dust and debris. The units must not be operated under any circumstances without an air filter in place.

PACKING LIST

Items packed inside the unit:

- (1) Filter Bracket
- (1) Filter Clip

LOCATION

The SPX is designed for through-the-wall installation. The interior portion of the unit is surrounded by a closet with a rear access (Fig. 1). The vertical discharge allows for ducting to the top of the room for best air circulation and elimination of cold drafts on occupants. The exterior (grille side) of the unit must have no obstructions (trees, landscape materials, etc.) within 18 inches. Do not locate two units adjacent to each

other on an inside corner or where they may exhaust into each other.

Provisions should be made to allow access to the indoor side of the unit for installation and inspection. The closet or access panel opening must be centered with the exterior wall opening and be at least 24" wide by 84" tall. Three (3) inches of unobstructed space is required on all sides of the SPX to allow for adequate air flow. At least 27 inches of unobstructed space should be provided in front of the access door to permit

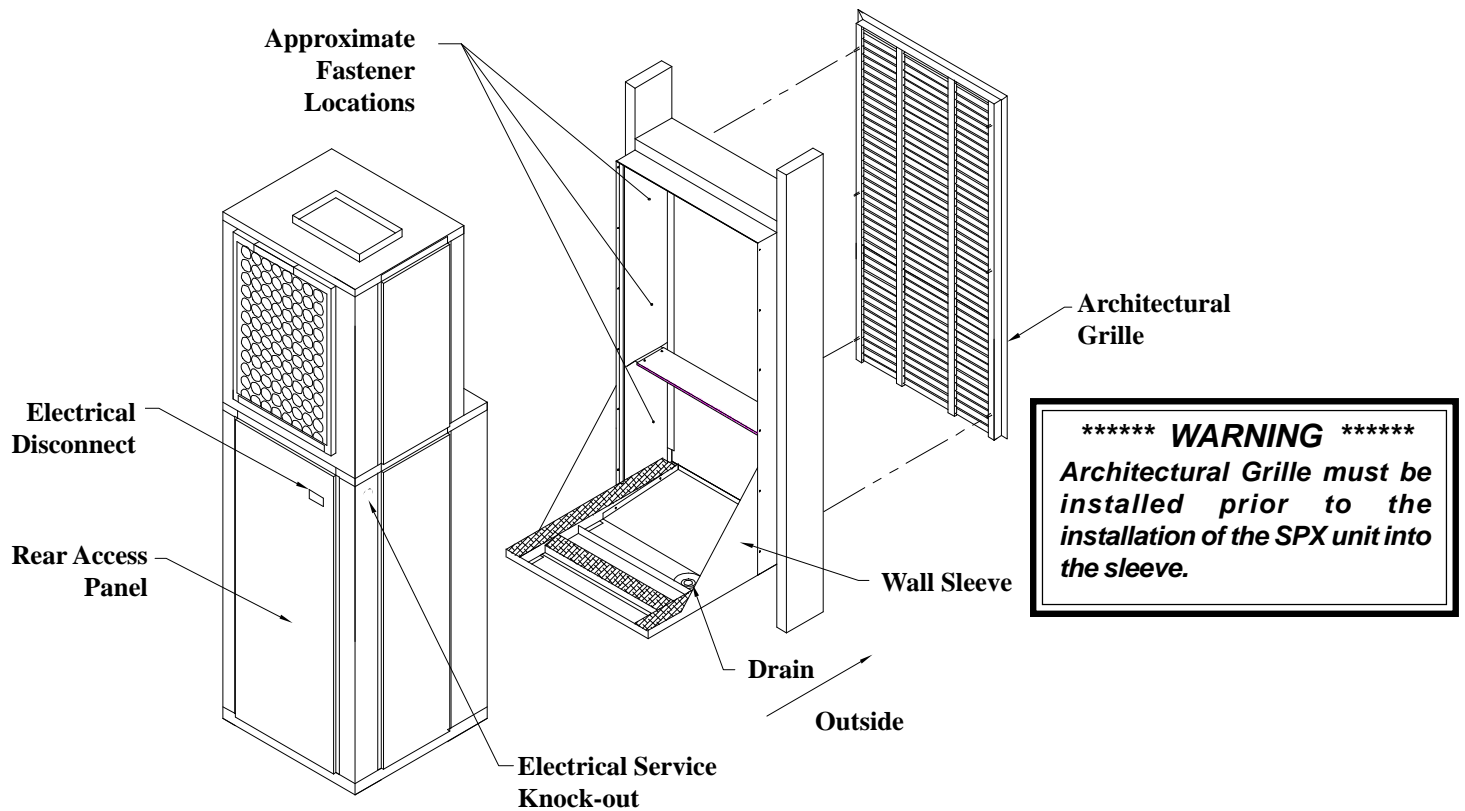

Figure 2 - General Assembly

removal of the unit should repair and inspection be required.

For installations requiring access panels refer to unit brochure for panel dimensions.

WALLSLEEVE INSTALLATION

Refer to installation instructions packed with wall sleeve to assemble and mount it in the wall. Before unit installation, make sure sleeve components are not damaged, drain line is unobstructed and leak free. Check all seals to ensure that they are in position and un-damaged. Ensure that the bottom of the wall sleeve is pitched 1/2 bubble toward the outside of the building so that rain water will drain to the outside (Fig. 4). Securely fasten the Architectural grille to the front of the sleeve using the supplied hardware.

******* WARNING *******
After sleeve installation ensure that the sleeve seal is in contact with the sleeve sides. Any air gaps must be sealed or outdoor air and/or water leakage will occur.

******* WARNING *******
Make sure a high grade non-hardening sealant approved for exterior use has been applied between edge of the sleeve and the structure, on the inside and outside walls, to prevent air and water from migrating inside (Fig. 4).

ELECTRICAL

All wiring must comply with local and national code requirements. Any alteration of the internal wiring will void UL certification and manufacturer's warranty.

Nameplate data indicates the operating voltage, phase, ampacity, maximum over current protection and minimum voltage. Units must never be installed or operated where voltage exceeds the nameplate voltage by more than 10%. Failure of the compressor as a result of operation with improper voltage voids the compressor replacement warranty.

The unit comes with a factory supplied disconnect, however, the contractor is responsible for providing over current protection on the branch circuit. Refer to the unit wiring diagram for single point electrical connection.

These units are provided with a Class 2 transformer for 24 volt control circuits. Should any add-on equipment also have a Class 2 transformer furnished, care must be taken to prevent interconnecting outputs of the two transformers by using a thermostat with isolating contacts.

******* WARNING *******
There must be a minimum 3" clearance maintained around the SPX chassis on all sides for adequate airflow to achieve optimum performance. These guidelines give minimum spacing requirements only. It is acceptable to go beyond these limits at any time.

INSTALLATION

1. Ensure that properly sized duct work is in place to mate to the supply connection on the SPX.

2. Remove the two clips holding the unit to the shipping pallet and remove unit from the shipping pallet.

3. Before setting unit into closet, remove upper side access panels and inspect the evaporator blower to ensure that the wheel turns freely without rubbing on the housing.

Note: Remove the styrofoam shipping block supporting the blower assembly.

Replace upper access doors prior to completing installation.

4. Remove disconnect and the rear access door to get to the loose items described in the packing list. Check all electrical connections and check the condenser fan to see that it turns freely. Note nameplate voltage, amperage and fuse size for proper power supply.

5. The SPX is equipped with bend out flanges (Fig. 3), next to the evaporator coil, for the purpose of attaching a return air duct. If ducted return air is required these flanges must be bent 90 degrees away from the face of the evaporator coil along the perforations.

Note: If the unit will not be connected to a fixed return duct these flanges must be broken off of the unit.

6. If an air filter is to be applied to the unit install the filter bracket by inserting the tab portion of the rack between the insulation and middle plate under the drain pan (Fig. 3). Place a 20" x 24" x 1" filter into the filter rack. Insert the two tabs on the filter clip into the slots above the evaporator and hook the front flange under the filter flange to hold the filter in place.

7. A fresh air make up vent is located on the lower left side door (Fig. 3). Remove one screw and rotate the plate to expose the desired amount of vent opening. Replace the screw to hold the door in desired location.

8. Ensure that the wall sleeve is installed squarely and is secure before

installing the unit.

Note: After removing the construction debris guard, inspect the sleeve seal, which is supplied with the sleeve, to ensure that it is properly secured and aligned (Fig. 2). Use a high grade non-hardening sealant to close any gaps that may exist between the seal and the wall of the sleeve.

9. After the seal is inspected, lift the unit onto the base of the sleeve and slide the unit forward to engage the seal. The unit is fully engaged when the upper housing of the SPX is 1/2" away from the top inside edge of the sleeve.

10. Check that the unit is completely seated on all four sides against the wall sleeve seals.

***** **WARNING** *****

After removing the construction debris guard, check the bottom of the pan to ensure that it is sloped one half bubble toward the outside. Ensure that the bottom of the pan and drain are clear of obstruction and operational.

***** **WARNING** *****

If unit is not sealed completely, water and/or outside air will infiltrate into the closet.

If necessary seal any openings that may exist.

11. Connect properly sized electrical service to the disconnect block.

12. Install a factory approved or equivalent thermostat according to

***** **WARNING** *****

SPX Heat Pump units operate with the reversing valve energized in the HEATING mode. The thermostat must be wired or configured accordingly or the unit will not operate properly.

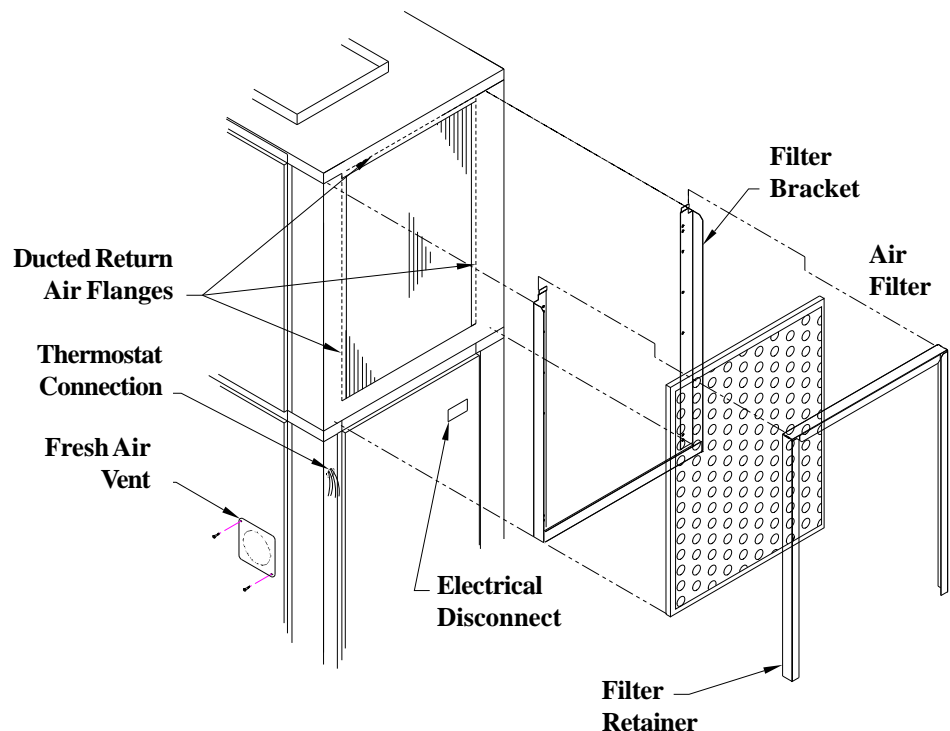

Figure 3 - Filter Bracket Detail

directions furnished with the thermostat. The thermostat should be located on an inside wall where it will not be affected by drafts, sunlight or any other heat producing appliances. Connect thermostat wires to the thermostat following the wiring diagram attached to the unit.

13. Connect low voltage thermostat wires from remote thermostat to the SPX unit (Fig. 3).

14. Install ductwork onto unit discharge and ensure that the connection is leak free. A flexible boot connection may be desirable to provide for more convenient installation and removal of the SPX unit.

15. Replace the rear access panel and disconnect.

CONDENSATE DRAIN

The SPX is designed so that the wall sleeve is the principle drain pan. Drain tubing is factory installed which drains evaporator condensate through the bottom of the unit which then is allowed to drain into the wall sleeve pan.

Note: When preparing unit for installation check to ensure that the drain tubing from the evaporator is securely attached to the copper nipple in the pan under the compressor. The wall sleeve has a 3/4 NPT nipple located in the bottom for connection to a drain (Fig. 4). A trap may be required in the condensate drain line to prevent sewer gas from escaping into the room.

Prior to unit installation ensure that the drain is unobstructed and leak free.

AIR FILTER

******* WARNING *******
SPX units must not be operated under any circumstances without an air filter in place.

All indoor return air must be filtered. The preferred methods are:

1. Use the factory supplied filter kit which attaches to the inlet of the evaporator and accepts a

20" x 24" x 1" field supplied throwaway type filter.

2. Use the filter kit supplied with the access panel which accepts a 20" x 20" x 1" throwaway type filter.

3. Install a filter in the return grille mounted in the wall. Any field installation of an air filter means must provide for use of a disposable filter which is no smaller than the face area of the evaporator coil.

The air filter should be cleaned or replaced every 30 days or more frequently if severe conditions exist.

EVAPORATOR BLOWER SPEEDS

The unit contains a direct drive, multi-speed blower. The proper speeds have been preset at the factory for heating and cooling. Refer to wiring diagram for recommended blower speeds for specific models.

OPERATING INSTRUCTIONS

Operation of the unit is automatic and will provide heating and cooling depending on the setting of the thermostat.

Note: Loosen compressor mounting nuts if unit vibration is excessive.

******* WARNING *******
All panels must be installed and disconnect switch must be in place before operating unit.

SYSTEM CHECK

Cooling/Electric Heat Units

1. Set thermostat system switch to "Off" position and fan switch to "Auto" position. Apply power to the SPX unit.

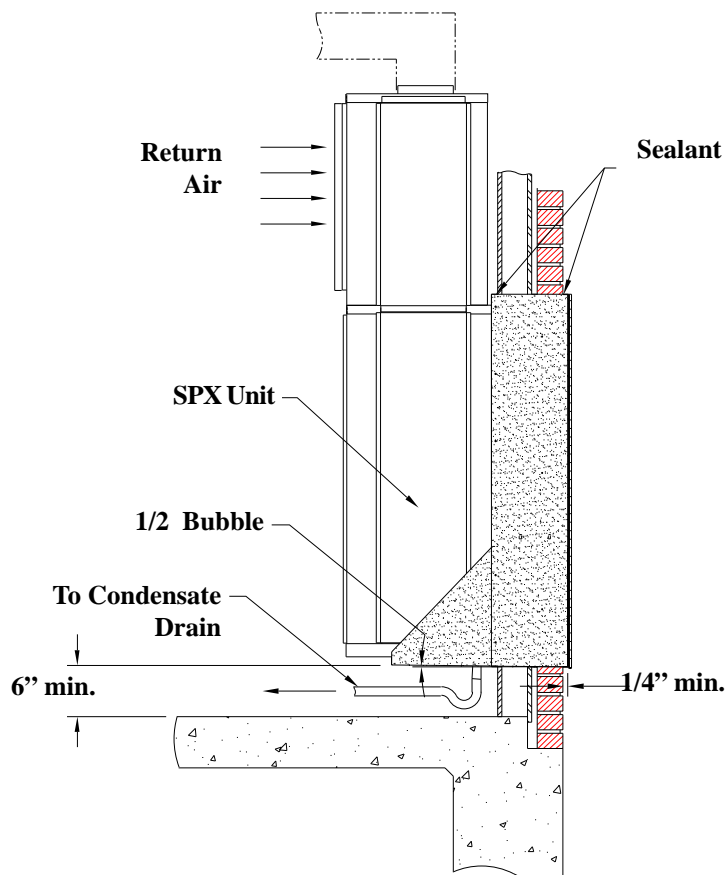

Figure 4 - Side View

Note: The SPX employs a random reset timer which delays unit operation up to 3 minutes following initial power application. Electronic thermostats may also employ internal reset timers which may further delay any changes which are made to the operation of the unit.

2. Set fan switch to "On", indoor blower should operate after the reset timer cycle is complete.

3. Return fan switch to "Auto", indoor blower should de-energize.

4. Set system switch to "Cool" and lower thermostat set point to coldest setting. The compressor should energize as well as the outdoor fan and indoor blower.

5. Return thermostat set-point to a temperature warmer than room temperature and the compressor and outdoor fan should de-energize. The indoor blower should remain in operation for an additional 45 seconds, then de-energize.

Note: The SPX employs a compressor short cycle delay (~ 3 minutes) which will not allow the compressor to immediately restart following shut down. Additional delays may be experienced if using an electronic digital thermostat.

6. Move system switch to "Heat" and raise thermostat to a set point higher than room temperature. The indoor blower and electric heating element(s) should energize.

7. Return system switch to "Off" position.

Note: The SPX features a low ambient compressor lock out switch which will not let the compressor energize in either cooling or heat pump mode when the outdoor ambient temperature is below 40 degrees F.

SYSTEM CHECK

Heat Pump Units

1. Set thermostat system switch to "Off" position and fan switch to "Auto" position. Apply power to the SPX unit.

Note: The SPX employs a random reset timer which delays unit operation up to 3 minutes following initial power application. Electronic thermostats may also employ internal reset timers which may further delay any changes which are made to the operation of the unit.

2. Set fan switch to "On", blower should operate after the reset timer cycle is complete.

3. Return fan switch to "Auto", blower should de-energize.

4. Set system switch to "Cool" and lower thermostat set point to coldest setting. The compressor should energize as well as the outdoor fan and indoor blower.

5. Return thermostat set-point to a temperature warmer than room temperature and the compressor and outdoor fan should de-energize. The indoor blower should remain in operation for an additional 45 seconds, then de-energize.

Note: The SPX employs a short cycle delay (~ 3 minutes) which will not allow the compressor to immediately restart following shut down. Additional delays may be experienced if using an electronic digital thermostat.

6. Move system switch to "Heat" and raise thermostat to a set point slightly higher than room temperature (less than 2 degrees). The compressor, outdoor fan and indoor blower should energize.

7. Raise set point to more than 2 degrees and the electric heaters should energize. The compressor and condenser fan will immediately de-energize. The compressor will remain locked out and the electric heat operating until the thermostat satisfies.

Note: The SPX employs a compressor lock out which will not allow the compressor and electric heaters to energize at the same time.

8. Lower the set point to less than room temperature and the system should de-energize.

9. Return system switch to "Off" position.

MAINTENANCE

Periodic maintenance is limited to:

1. Replacing the air filter monthly or more frequently if unusual conditions are encountered. Air filter size is 20" x 24" x 1" when using the factory filter frame and 20" x 20" x 1" when using the access panel.

2. Cleaning the outdoor coil of foreign material such as lint, dust, leaves or other obstructions as necessary.

3. Checking drain line and removing obstructions as necessary.

***** WARNING *****

It is illegal to discharge refrigerant into the atmosphere. Use proper reclaiming methods and equipment when installing or servicing this unit. Service should be performed by a QUALIFIED service agency. The refrigerant system contained in the unit normally requires no maintenance since it is a closed, self-contained system.

If servicing or major repairs are required, the complete unit can be removed as follows:

1. Disconnect the electrical power circuit supplying the unit.
2. Remove disconnect pull and low voltage thermostat connector.
3. Remove rear access panel.
4. Remove supply duct from top of unit.
5. Slide unit back out of sleeve.
6. Unit may be removed from closet.

To reinstall unit, use the installation procedure outlined above.

MAINTENANCE UPDATES

For a current copy of the Maintenance Program log on to www.firstco.com and look under "Product Information"

***** WARNING *****

Replace all access panels before turning on main power.

***** WARNING *****

SPX Heat Pump units operate with the reversing valve energized in the HEATING mode. The thermostat must be wired or configured accordingly or the unit will not operate properly.

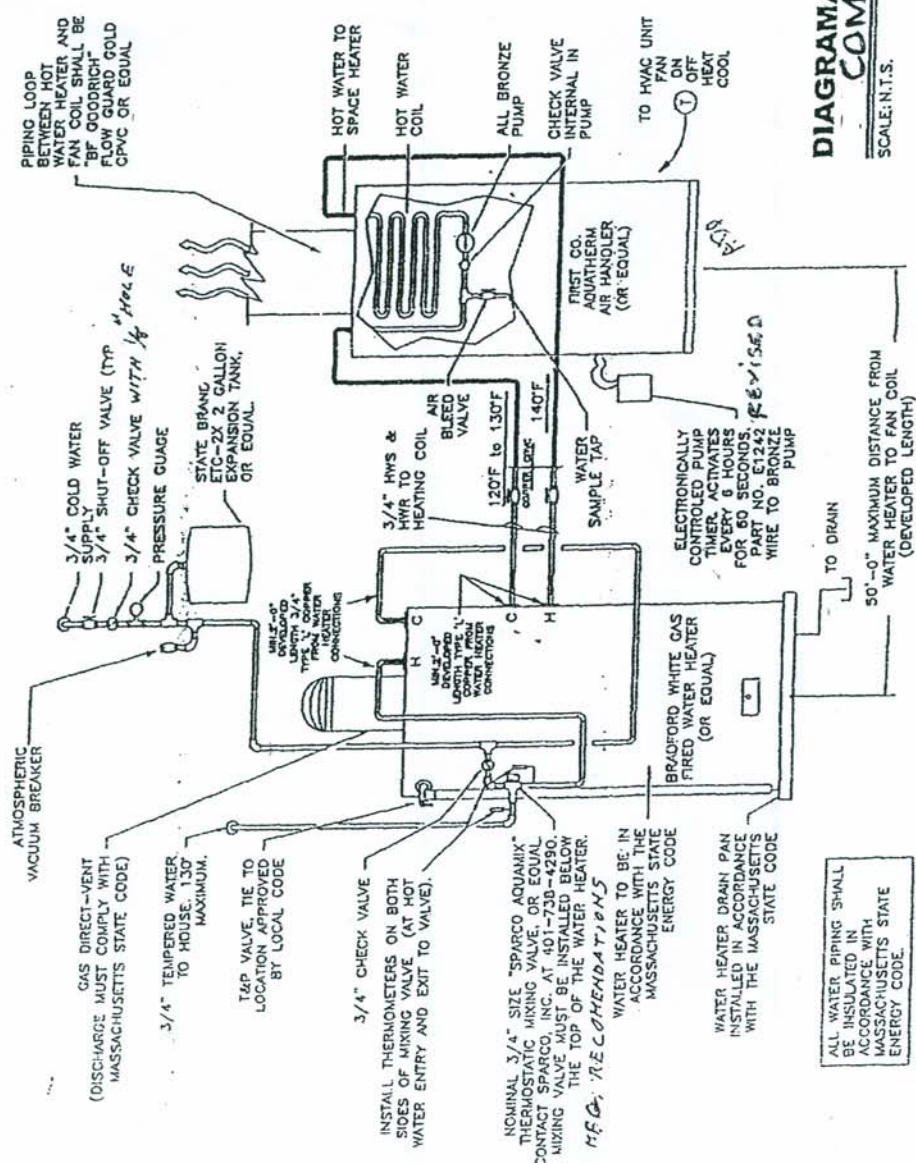

PIPING LOOP BETWEEN HOT WATER HEATER AND FAN COIL SHALL BE OF OCCURICH FLOW GUARD GOLD CPVC OR EQUAL

3/4" COLD WATER SUPPLY
3/4" SHUT-OFF VALVE (TYP. 1/2" HOLE)
3/4" CHECK VALVE WITH 1/2" HOLE
PRESSURE GAUGE

STATE BRASS, ETC.-2X 2 GALLON EXPANSION TANK, OR EQUAL

ATMOSPHERIC VACUUM BREAKER

GAS DIRECT-VENT (DISCHARGE MUST COMPLY WITH MASSACHUSETTS STATE CODE)

3/4" TEMPERED WATER TO HOUSE, 130° MAXIMUM.

T&P VALVE, TIE TO LOCATION APPROVED BY LOCAL CODE

3/4" CHECK VALVE

HOT WATER TO SPACE HEATER
HOT WATER COIL

3/4" HWS & HWR TO HEATING COIL
AIR BLEED VALVE
120°F TO 130°F
140°F

UNION-OR EQUIVALENT LENGTH 3/4" TYPE 'L' COPPER PIPING FOR WATER HEATER CONNECTIONS

UNION-OR EQUIVALENT LENGTH 3/4" TYPE 'L' COPPER PIPING FOR WATER HEATER CONNECTIONS

INSTALL THERMOMETERS ON BOTH SIDES OF MIXING VALVE. (AT HOT WATER ENTRY AND EXIT TO VALVE).

NOMINAL 3/4" SIZE "SPARCO AQUAMIX" THERMOSTATIC MIXING VALVE, OR EQUAL CONTACT SPARCO, INC. AT 401-738-4290. MIXING VALVE MUST BE INSTALLED BELOW THE TOP OF THE WATER HEATER.

WATER HEATER TO BE IN ACCORDANCE WITH THE MASSACHUSETTS STATE ENERGY CODE

ALL BRONZE PUMP
CHECK VALVE INTERNAL IN PUMP

ELECTRONICALLY CONTROLLED PUMP TIMER, ACTIVATES EVERY 6 HOURS FOR 60 SECONDS. PART NO. E1242 WIRE TO BRONZE PUMP

TO DRAIN
50'-0" MAXIMUM DISTANCE FROM WATER HEATER TO FAN COIL (DEVELOPED LENGTH)

WATER HEATER DRAIN PAN INSTALLED IN ACCORDANCE WITH THE MASSACHUSETTS STATE ENERGY CODE

TO HVAC UNIT
FAN ON
HEAT
OFF
COOL

FIRST CO. AQUATHERM AIR HANDLER (OR EQUAL)

REVISÉD

MASSACHUSETTS BOARD OF PLUMBERS AND GAS FITTERS
APPROVED FOR SUBJECT TO RULES AND REGULATIONS
STATE OF MASSACHUSETTS
CHECKED BY: [Signature]
DATE: 4/2/02
FOR THE BOARD
PLAN EXAMINER

DIAGRAMATIC LAYOUT SYSTEM
COMBO
SCALE: N.T.S.



NOTE: STATE OF MA.: 248 CMR CODE OF THE STATE OF MA. REQUIRES A PUMP TIMER. (60 SECONDS EVERY 6 HOURS)

**STATE OF MASSACHUSETTS PIPING DIAGRAM
UNITS WITH HOT WATER HEATING**