

UC-HW SERIES FAN COIL UNIT

INSTALLATION, OPERATION & MAINTENANCE INSTRUCTIONS

****WARNING TO INSTALLER, SERVICE PERSONNEL AND OWNER****

Altering the product or replacing parts with non authorized factory parts voids all warranty or implied warranty and may result in adverse operational performance and/or a possible hazardous safety condition to service personnel and occupants. Company employees and/or contractors are not authorized to waive this warning.

GENERAL

The manufacturer assumes no responsibility for equipment installed in violation of any code requirement.

These instructions give information relative to the installation of UC-HW fan coil units only. For other related equipment refer to the proper instructions.

Material in this shipment has been inspected at the factory and released to the transportation agency in good condition. When received, a visual inspection of all cartons should be made immediately. Any evidence of rough handling or apparent damage should be noted on the delivery receipt and the material inspected in the presence of the carrier's representative. If damage is found, a claim should be filed against the carrier immediately.

FAN COIL UNIT

The installer must adhere strictly to all local and national code requirements pertaining to the installation of this equipment.

These units are designed to be installed vertically in the upflow position by the following mounting means:

Hung on closet wall

Using mounting kit **90PK3**, air handler may be wall mounted. Brackets and screws are provided for both the closet wall and the air handler.

It is recommended that sound isolating material be installed to prevent any undesired transfer of sound.

Recessed in a wall

Installation of the fan coil recessed into a partition wall with it's recommended framing is shown in figure 1. **Note: the front face of the unit must be installed flush with the dry wall.** This application requires the optional louvered wall panel which must be ordered separately. Wall panel with frame is secured

to the studs by screws or nails after the dry wall has been installed. Refer to figure 2 and 3.

Closet Platform Front Return

Fan coil is to be set on a platform and secured by screws or nails. Sufficient space for drain piping is required under the platform.

All fan coil units are U.L. Listed for installation with zero inches clearance to

******* WARNING *******

Extreme caution must be taken that no internal damage will result if screws or holes are drilled into the cabinet.

combustible materials. This includes the fan coil cabinet, discharge plenum and connecting ducts. Sufficient clearance must be provided at the front of the fan coil to allow access to electrical controls and removal of the motor /blower assembly for servicing. This clearance distance should be approximately the same as the depth dimension of the fan coil unit.

******* WARNING *******

Unit must not be operated during building construction due to excessive airborne dust and debris. The unit must not be operated under any circumstances without an air filter in place.



AIR DISTRIBUTION DUCTS

All duct work must be installed in accordance with National Fire Protection Association Codes 90A and 90B. Ducts should be adequately insulated to prevent condensation during the cooling cycle and to minimize heat loss during the heating cycle. All return air must be filtered to prevent dirt buildup on the coil surface. If there is no ducted return, applicable installation codes may limit the unit to installation only in a single story residence. In many cases it is acceptable to use ducting of the same size as the fan coil connections. However, unique arrangements or long duct runs must be confirmed by a local professional. The manufacturer will not be responsible for misapplied equipment.

ELECTRICAL

All wiring must comply with local and national code requirements. Units are provided with wiring diagrams and nameplate data to provide information required for necessary field wiring. Refer to figure 2 for points of entry of the wiring into the cabinet.

******* WARNING *******

Any devices such as fan switches or thermostats that have been furnished by the factory for field installation must be wired in strict accordance with the wiring diagram that is supplied with the unit. Failure to do so could result in damage to components and will void all warranties.

These units may be provided with a Class 2 transformer for 24-volt control circuits. Should any add-on equipment also have a Class 2 transformer furnished, care must be taken to prevent interconnecting outputs of the two transformers by using a thermostat with isolating contacts.

INSTALLATION PRECAUTIONS

Installation of this fan coil should only be performed by a licensed contractor to ensure proper installation and the safety of the installer. The following are some precautions to be followed for typical installations.

- Always use proper tools and equipment.
- No wiring or other work should be attempted without first ensuring that the fan coil is completely disconnected from the power source and locked out. Always verify that a good ground connection exists prior to energizing any power sources.
- Always review the nameplate on each unit for proper voltage and control configurations. This information is determined from the components and wiring

******* WARNING *******

Do not touch any rotating component with any object. Damage to the equipment and personal injury can occur.

of the unit and may vary from unit to unit.

- When soldering or brazing to the unit, it is recommended to have a fire extinguisher readily available. When soldering close to valve packages or other components, heat shields or wet rags are required to prevent damage.
- When the fan coil unit is in operation components are rotating at high speeds.
- Units must be installed level to ensure proper drainage and operation.
- Check unit prior to operation to ensure that the condensate water will drain toward the drain connection. An overflow drain or an auxiliary drain pan under the fan coil may be required as a back up to a clogged primary drain.
- Be sure that the drain pan is free from foreign material prior to start up.
- Check filter media installation to ensure that it is installed correctly. Use the directional arrows or other information on the filter to determine the proper flow direction.

NOISE

These fan coil units are designed for quiet operation, however, all air conditioning equipment will transfer some amount of noise to the conditioned

space. This should be taken into consideration when planning the location of the equipment.

COOLING COIL PIPING

These fan coil units are supplied with a direct expansion refrigerant coil. The suction and liquid lines must be sized in accordance with the outdoor unit manufacturer's recommendations.

Condensate drain lines must be installed with adequate slope away from the unit to assure positive drainage. Since the drain pan is located on the suction side of the blower, a negative pressure exists at the drain pan and a minimum trap of 1-1/2 inches must be provided in the drain line to assure proper drainage.

NOTE: *If a Condensate Overflow Shut-off Switch, that is designed to be installed in the drain line, is used in place of a secondary drain line, then the cut-off switch should be located in the primary drain line between the fan coil unit and the P-trap.*

UC-HW RECESSED WALL MOUNTING

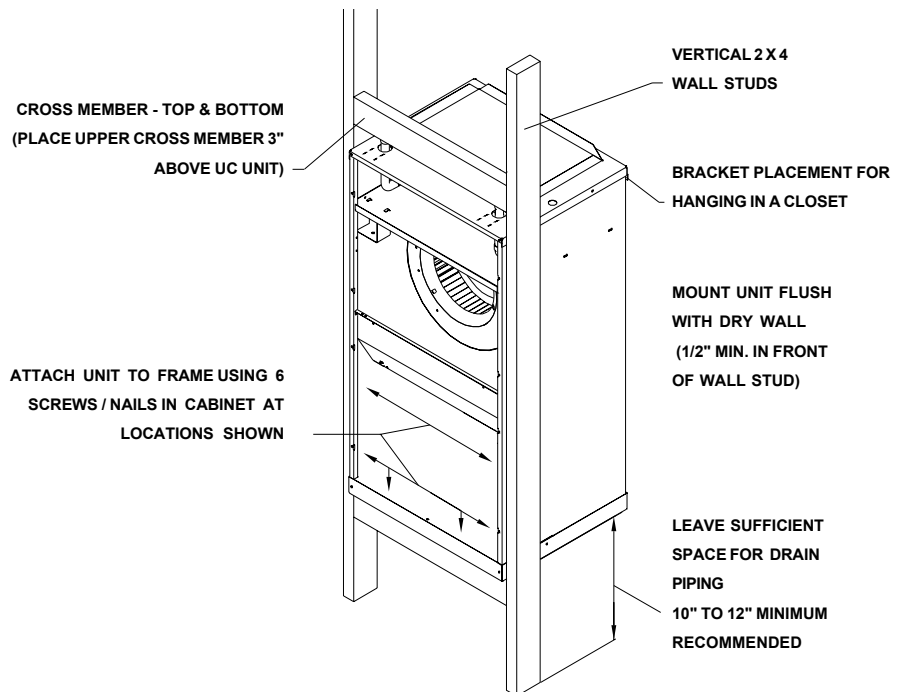

SUPPORT FRAMING
Figure 1

HOT WATER COIL PIPING PRECAUTIONS

- Flush all field piping prior to connection to remove all debris.
- Use wet cotton rags to cool valve bodies when soldering.
- Open all valves (midway for hand valves, manually open on motorized valves) prior to soldering.
- When soldering to bronze or brass, heat the piping while in the socket/cup and begin introducing the solder when the flux boils rapidly. Avoid direct flame into the solder joint.
- Heat can only be applied to the cup of the valve body for a minimal time before damage occurs (even with the use of wet rags).
- Avoid rapid quenching of solder joints as this will produce joints of inferior quality.

******* WARNING *******

When connecting piping to fan coil units, do not bend or reposition the coil header tubing for alignment purposes. This could cause a tubing fracture resulting in a water leak when water pressure is applied to the system.

- Connect all piping per accepted industry standards and observe all regulations governing installation of piping systems. When all connections are complete the system must be pressure tested. Repair any solder joint leaks and gently tighten any leaking valve packing nuts and piping accessories as required. Hydronic systems are not de-

signed to hold pressurized air and should only be tested with water.

HOT WATER COIL PIPING

Refer to Flow Control Module installation instructions for proper pump installation, if used.

The hot water coil connections are 3/4 inch nominal (7/8" OD) copper. The hot water supply to the fan coil should be on the right when facing the fan coil upright and from the front.

******* WARNING *******

An expansion tank may be required if a back-flow preventer is installed in the system.

All piping between the water heater and fan coil unit should be copper and should not exceed 200 feet of total piping. It is recommended that 3/4" nominal (7/8" OD) piping should be used on all UC-HW units to prevent excessive head pressure losses. (Consult the factory for other piping applications.)

It is also recommended that all piping be adequately insulated to prevent freezing when piping is run in an unconditioned space.

Solder Connections - All copper joints in the water lines must be made with **low temperature - non lead solder.**

"T" Connections (at the water heater)-

Water lines to and from the fan coil unit must be taken from the horizontal connection of the "T" fittings in the vertical hot and cold water supply lines at the water heater. This ensures that any air in the system will be purged each time water is used in the dwelling. See figure 4.

Isolation Valves - Two valves are recommended to be installed within the circulating loop to permit servicing of the system if required and to assist in purging the system.

NOTE: Hot water coil freeze protection is available for applications where the fan coil is located in ambient air locations (attics, crawl spaces, etc.) or within structures that may be unoccupied during freezing conditions. Consult the factory for additional information.

OPERATION AND MAINTENANCE

Pre-start Check

- Check that supply voltage matches nameplate data.
- Ensure that the unit is properly grounded.
- With power off, check blower wheel set screw for tightness and ensure that the blower wheels rotates freely and quietly.
- Check that the refrigerant coil connections and piping have been leak checked and insulated as required.
- Check that the water coil, valves and piping have been leak checked and insulated as required.
- Ensure that all air has been vented from the hot water coil.

NOTE: *It may require purging several gallons of water so have a means of discarding the water.*

- Install all panels.
- Install any filters which may have been removed during the installation process.

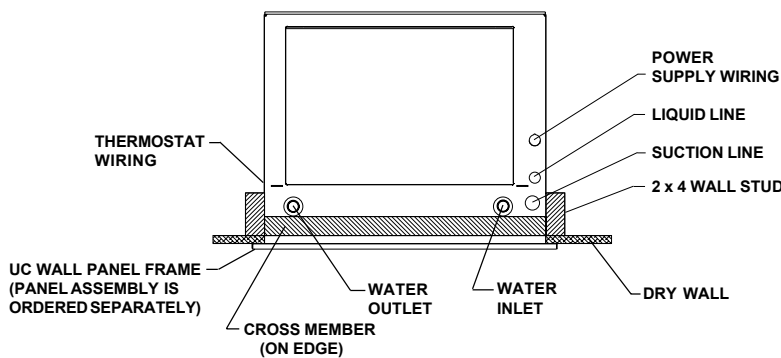

**INSTALLED UNIT
TOP VIEW
Figure 2**

Note: Front edge of unit to be flush with dry wall.

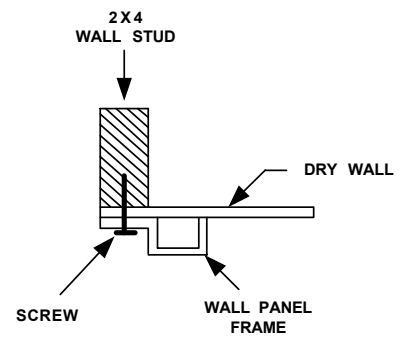

**DETAIL OF WALL PANEL FRAME
INSTALLATION**

Figure 3

******* WARNING *******

- *Always wear eye protection.*
- *When fan coil is operating, some components are operating at high speeds. Personal injury can result from touching these items with any object*
- *All electrical and service access panels must be returned and secured in their proper place.*
- *Clear surrounding area of all tools, equipment and debris.*
- *Check the entire unit to ensure it's cleanliness.*

Start-up and Maintenance

Before start-up, all of the components should be given a thorough check. Optimal operation of this equipment requires cleanliness. Often after installation of this equipment additional construction activities occur. Care must be taken to protect the equipment from debris during these construction phases.

Fan

The fan should be inspected and cleaned, in conjunction with maintenance of the motor and bearings. It is important to keep the wheel clean in order to avoid imbalance and vibration.

Motor

Check motor connections to ensure that they are secure and made in accordance with the wiring diagram.

The blower motor should be cleaned annually.

Coil

Any dust or other contaminants which accumulate on the heat transfer surfaces interferes with the air flow and impairs heat transfer. The coil must be kept clean by any of the following methods.

- Cleaning with low pressure compressed air.
- Flushing or rinsing with water (a detergent is advisable for greasy surfaces).

Filter

The air filter should be cleaned or replaced as often as necessary to prevent restriction of air flow. Always replace the filter with the same type as originally furnished.

******* WARNING *******

The manufacturer does NOT WARRANT equipment subjected to abuse. Metal chips, dust, drywall tape, paint over spray, etc. can void warranties and liability for equipment failure, personal injury and property damage.

Drain Piping

The drain should always be:

- Connected or piped to an acceptable disposal point sloped away from the unit at least 1/8" per foot
- Checked before summer operation
- Periodically checked during summer operation

Preventative Maintenance

To achieve maximum performance and service life of each piece of equipment a formal schedule of regular maintenance should be established and maintained by a licensed contractor.

HEATING CYCLE

START - UP

- 1) Fill the water heater. Open a hot water faucet while filling the water heater to vent the air. When the tank is full and all the air is purged, close the faucet.
- 2) Ignite the water heater and set the thermostat to 140 degrees.
- 3) Purge the air handler's hot water coil and lines.

NOTE: *It may require purging several gallons of water so either have a bucket available or a means of discarding the water.*

Close valve number 2 and open valve number 3. (See figure 4) Next, open the air bleed valve. When all of the air is purged from the lines close valve number 3 and open valve number 2. After all the air is purged from the coil and lines, open both valve number 1 and 2 and close the air bleed valve.

- 4) Switch the room thermostat to the "Heat" position and raise the temperature setting to a position approximately ten degrees above room temperature.

The pump should energize and begin circulating the hot water through the coil. If the pump is operating

******* WARNING *******

To prevent pump damage, the fan coil unit should not be energized for heating until the hot water coil and all water lines have been purged of air.

properly and the water temperature in the water heater has reached the set point, then the hot water inlet at the fan coil unit will be hot. If the pump is running but hot water is not circulating, open the air bleed valve long enough to purge any remaining air from the hot water lines and coil. This will allow the pump to begin circulating hot water.

******* WARNING *******

Hot water can cause scalding. A hot water mixing valve can be applied to the system to temper domestic water draw.

- 5) The water heater thermostat should be adjusted so that the water temperature entering the hot water coil is as close to 140 degrees as possible with the system energized and operating long enough for all temperatures to stabilize.

PUMP REPLACEMENT (If Flow Control Module is installed)

Disconnect electrical power before servicing the unit.

To replace the circulator pump, close the isolation valves and relieve the water pressure within the heating loop. Disconnect the pump's 115 volt power lines within the control box and remove the four hex head screws securing the pump motor to the pump's volute.

Reverse the above steps for reassembling the pump, however make sure that the pump or volute has the rubber o-ring in place before assembling.

CHECK VALVE REPLACEMENT

Disconnect electrical power before servicing the unit.

To replace the internal check valve, close the isolation valves and relieve the water pressure within the heating loop.

Remove the four hex head screws securing the pump motor to the pump's volute and remove. The check valve is located in the volute.

Rotate the check valve to release and remove from the volute.

Reverse the above steps for re-installing a check valve, however make sure that the pump or volute has the rubber o-ring in place before assembling.

TYPICAL PIPING SCHEMATIC w / Flow Control Module

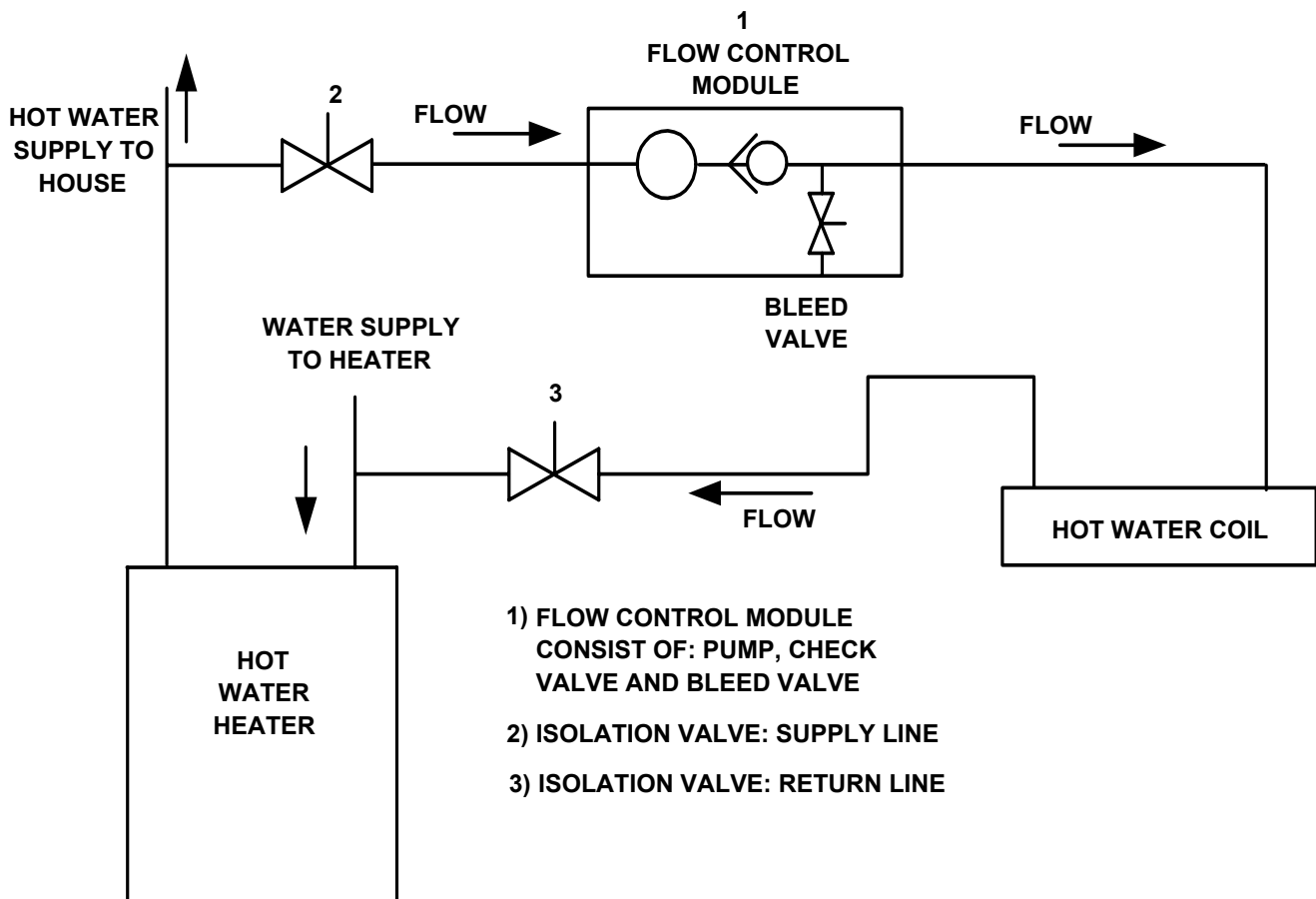

Figure 4