

First Co.

USM Series
VERTICAL / HORIZONTAL
UNCASED COIL
HEAT PUMP or Cooling Only
1-1/2 thru 5 TONS

Description:

The **USM** series coil can be field installed into an air handler with sufficient space. A piston-type metering device is utilized for maximum flexibility. Optional R-22 or R-410A field installed TXV kits are available. **First Co's customer is ultimately responsible for confirming which fan coil models are compatible with selected outdoor unit(s) and which expansion valves (if any) are required. To determine approved indoor/outdoor matches, go to: www.firstco.com or contact the factory.**

HORIZONTAL DRAIN PANS ARE OPTIONAL AND MUST BE ORDERED SEPARATELY

FEATURES:

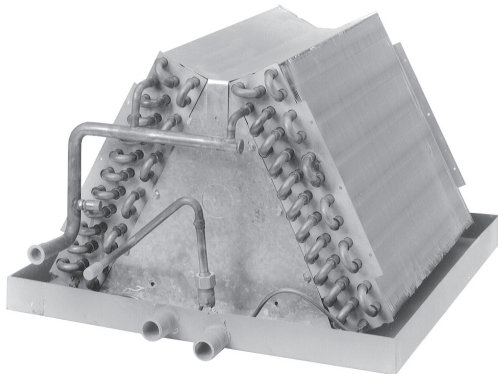

1. For use with **up to 14 SEER** condensing units.
2. **High efficiency** copper tube, aluminum fin coil with piston type metering device
3. Coils are circuited for **cooling only or heat pump** operation
4. **Sweat** refrigerant connections
5. 3/4" MPT **primary and secondary condensate drain connections**
6. Factory installed **equalizer connection** on coil header to facilitate field installation of expansion valve kits
7. **Coil drain pan** is coated for corrosion resistance

USM Series Evaporator Coils

PHYSICAL DIMENSIONS										
MODEL NUMBER	NOMINAL TONNAGE RANGE	A	B	C	D	E	F	G	LIQ. X SUCT. LINE OD SWT	FITS CABINET
USM318AP	1.5	12-3/4	18-1/2	19-1/4	3-1/2	3-3/8	3	8	3/8 X 5/8	20 X 20
USM424AP	1.5 - 2.0	12-3/4	18-1/2	19-1/4	3-1/2	3-3/8	3	8	3/8 X 5/8	20 X 20
USM330AP	2.0 - 2.5	13-3/4	18-1/2	22-1/4	3-1/2	3-3/8	3	8	3/8 X 3/4	20 X 23
USM436AP	2.5 - 3.0	15	18-1/2	22-1/4	3-1/2	3-3/8	3	8	3/8 X 3/4	20 X 23
USM348AP	3.5 - 4.0	18-1/2	19-3/4	27	5-1/2	3-3/4	4	8-5/8	1/2 X 7/8	21-1/4 X 28
USM460AP	4.0 - 5.0	18-1/2	19-3/4	27	5-1/2	3-3/4	4	8-5/8	1/2 X 7/8	21-1/4 X 28
USM460BP	4.0 - 5.0	18-1/2	23-1/4	27	5	3-3/4	6	10-3/8	1/2 X 7/8	25-1/4 X 28

Notes:

(1) Condensate drains are 3/4" MPT

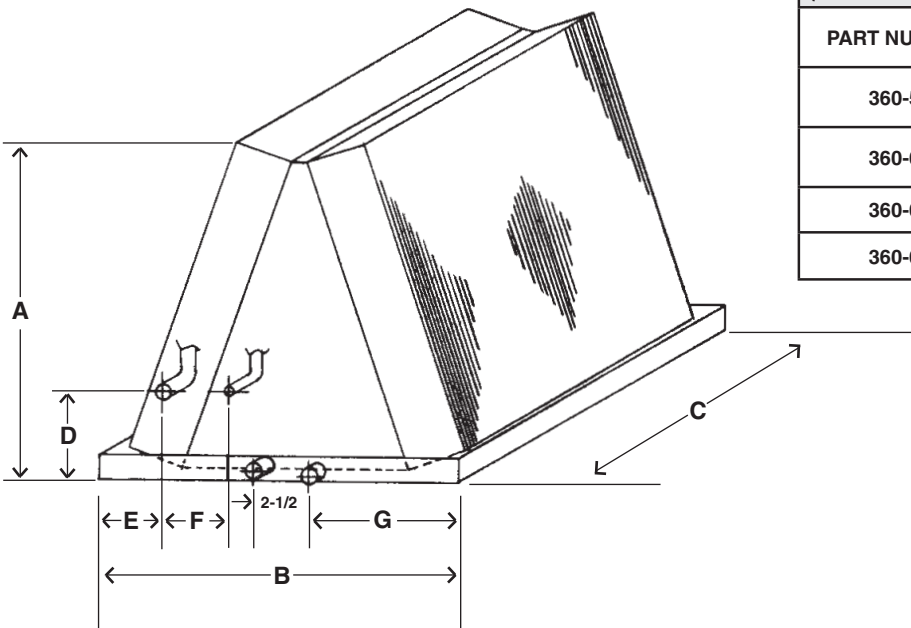

HORIZONTAL DRAIN PANS (For First Co. air handlers only - field installed)	
PART NUMBER	FITS FIRST CO. AIR HANDLER MODEL NUMBER
360-58	18XHBQB/XHBXB-HW/XMBX 24XHBQB/XHBXB-HW/XMBX
360-60	30XHBQB/XHBXB-HW/XMBX 36XHBQB/XHBXB-HW/XMBX
360-62	48XHBQB/XHBXB-HW/XMBX/60XMBX
360-62	60XHBQB/XHBXB-HW

In keeping with its policy of continuous progress and product improvement, First Co. reserves the right to make changes without notice. Maintenance for all First Co. products is available under "Product Maintenance" at www.firstco.com.

EXPANSION VALVE KITS (Heat Pump or cooling only) (FIELD INSTALLED)		
PART NO.	TYPE	FOR
9EVR22-4	R-22	USM318AP / USM424AP
9EVR22-5	R-22	USM330AP / USM436AP
9EVR22-6	R-22	USM348AP / USM460AP / USM460BP
9EVR410-3	R-410A	USM318AP / USM424AP
9EVR410-4	R-410A	USM330AP / USM436AP
9EVR410-5	R-410A	USM348AP / USM460AP / USM460BP

NOTES:

- Above expansion valve kits are approved for both cooling only (non heat pump) or heat pump applications.
- Valves are external equalizing, internal bleed.
- Valves mount inside unit cabinet

