

2 NEW HOT
WATER FURNACES
NOW AVAILABLE



FWA-AQ Series

FWA-HW Series

Multi-Position, Heating Only
Up to 109,200 BTUH Heating
305 to 1500 CFM



The **FWA-AQ / FWA-HW** products are compact, multi-position, cased air handlers that include hot water coils for hydronic space heating.

The **FWA-HW** series is specifically designed for boiler loop and does not include a circulating pump. The **FWA-AQ** series includes a factory installed circulating pump and is designed for connection to gas or oil-fired water heaters.

The cabinet is made of embossed galvanized steel and is fully insulated.

Note: FWA-AQ models State of MA, .248 CMR code of the state of MA requires a pump timer. (60 seconds every 6 hours)

Standard Features: (both products)

- Cabinets are embossed galvanized steel and fully insulated
- Compact size - 20" or 23" deep and only 27" tall
- Three or four motor speeds to chose from (single speed operation)
- Highly efficient copper tube / aluminum fin coils
- Upflow, downflow, or horizontal (left or right) installations
- Blower door safety switch
- Factory installed filter
- Manual air vent on coil
- 120/24V transformer and fan relay

Additional FWA-AQ Features:

- Circulating pump
- Easy-access hot water check valve

Optional Accessories:

- Remote "flow control" assembly for **FWA-HW** models (part # **940-3CV**). Mounts in hot water line external to unit.
- Freeze protector for units with circulating pump

FWA-AQ Series

FWA-HW Series

Multi-Position, Heating Only

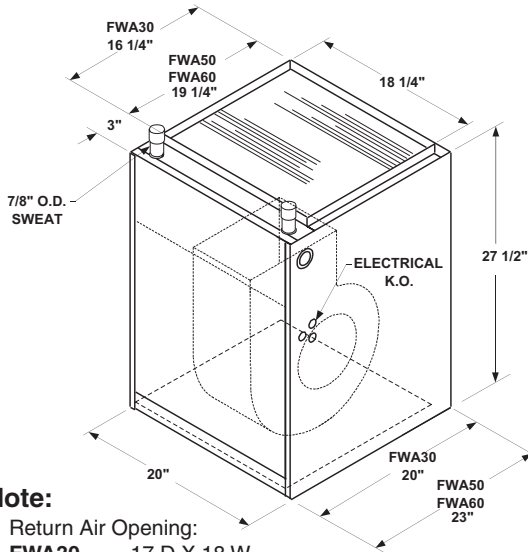

Note:

Return Air Opening:
FWA30 17 D X 18 W
FWA50/60 20 D X 18 W

Filter Size
FWA30 20 X 20 X 1
FWA50/60 20 X 22 1/4 X 1

FREEZE PROTECTOR	
KIT NUMBER	FOR
941-1	All FWA-AQ Models

FLOW CONTROL MODULES	
PART NUMBER	FOR
940-3-CV	All FWA-HW Models

Note:

Flow Control Modules are required when connecting to individual gas water heaters.



ELECTRICAL DATA					
UNIT MODEL	MOTOR HP (120V)	AMPS		MIN. CIR. AMPACITY	MAX HACR BREAKER
		MOTOR	PUMP		
FWA30-HW	1/5	2.7	---	4	15
FWA50-HW	1/2	8.1	---	10	15
FWA60-HW	1/2	8.1	---	10	15
FWA30-AQ	1/5	2.7	0.57	5	15
FWA50-AQ	1/2	8.1	0.57	11	15
FWA60-AQ	1/2	8.1	0.57	11	15

Note:

Motors are 120V multi-speed

In keeping with its policy of continuous progress and product improvement, First Operations reserves the right to make changes without notice. Maintenance for all First Co. products is available under "Product Maintenance" at www.firstco.com.

Catalog No. FWA209 (Replaces FWA508)

FWA30 PERFORMANCE DATA							
UNIT MODEL	GPM	P.D. (FT. WTR.)	MOTOR SPEED	CFM @ .15 ESP	BTUH (1000) AT ENTERING WATER TEMPERATURE		
					120°F	140°F	180°F
FWA30-HW	4	3.2	HIGH	930	28.0	39.2	61.6
			MED-HIGH	730	24.1	33.7	53.0
			MED-LOW	465	17.9	25.1	39.4
			LOW	305	13.6	19.0	29.9
FWA30-HW FWA30-AQ (3)	3	1.8	HIGH	930	26.5	37.1	58.3
			MED-HIGH	730	22.9	32.0	50.3
			MED-LOW	465	17.2	24.1	37.9
			LOW	305	13.1	18.3	28.8
FWA30-HW	2	0.83	HIGH	930	24.2	33.9	53.3
			MED-HIGH	730	21.1	29.5	46.4
			MED-LOW	465	16.1	22.5	35.4
			LOW	305	12.4	17.3	27.2

FWA50 PERFORMANCE DATA							
UNIT MODEL	GPM	P.D. (FT. WTR.)	MOTOR SPEED	CFM @ .15 ESP	BTUH (1000) AT ENTERING WATER TEMPERATURE		
					120°F	140°F	180°F
FWA50-HW	6	7.6	HIGH	1500	41.9	58.7	92.2
			MED-HIGH	1390	40.1	56.2	88.3
			LOW	1275	38.1	53.4	83.9
FWA50-HW FWA50-AQ (3)	3.5	2.9	HIGH	1500	37.7	52.8	83.0
			MED-HIGH	1390	36.3	50.8	79.8
			LOW	1275	34.5	48.3	75.9
FWA50-HW	2	1.1	HIGH	1500	32.4	45.4	71.3
			MED-HIGH	1390	31.4	43.9	69.0
			LOW	1275	29.9	41.9	65.8

FWA60 PERFORMANCE DATA							
UNIT MODEL	GPM	P.D. (FT. WTR.)	MOTOR SPEED	CFM @ .15 ESP	BTUH (1000) AT ENTERING WATER TEMPERATURE		
					120°F	140°F	180°F
FWA60-HW	6	4.3	HIGH	1385	49.6	69.5	109.2
			MED-HIGH	1300	47.6	66.6	104.7
			LOW	1225	45.7	64.0	100.6
FWA60-HW FWA60-AQ (3)	3.5	1.6	HIGH	1385	44.7	62.6	98.4
			MED-HIGH	1300	42.9	60.0	94.3
			LOW	1225	41.3	57.8	90.8
FWA60-HW	2	0.6	HIGH	1385	38.8	54.3	85.3
			MED-HIGH	1300	37.2	52.1	81.9
			LOW	1225	36.0	50.4	79.2

Notes:

- Heat BTU is at 70 degree EAT.
- ALL models are factory wired on high speed.
- FWA-AQ models with circulating pumps have fixed GPM of 3.0 or 3.5.

BLOWER DATA								
UNIT MODEL	MOTOR SPEED	CFM vs. EXTERNAL STATIC PRESSURE						
		0.10	0.15	0.20	0.25	0.30	0.40	0.50
FWA30-AQ FWA30-HW	High	950	930	910	885	860	790	710
	Med-Hi	740	730	720	700	680	630	560
	Med-Low	480	465	450	430	410	380	320
	Low	330	305	280	260	240	200	160
FWA50-AQ FWA50-HW	High	1530	1500	1470	1435	1400	1335	1265
	Medium	1410	1390	1370	1335	1300	1240	1180
	Low	1300	1275	1250	1225	1200	1150	1090
FWA60-AQ FWA60-HW	High	1420	1385	1350	1320	1290	1220	1150
	Medium	1330	1300	1270	1240	1210	1140	1075
	Low	1250	1225	1200	1170	1140	1085	1015

Note:

- ALL models are factory wired on high speed.