

R-410A
REFRIGERANT

First Co.[®]

SPXR-A / SPXR-HP-A Series Single Package Vertical Unit Straight Cool and Heat Pump 3/4 through 2 tons, up to 10 kW Electric Heat



"Rear install" shown

The **SPXR-A** Series "Suite 20" is a compact, through-the-wall single package vertical HVAC unit that delivers conditioned air from a single unit to multiple rooms. The **SPXR-A** series is available in straight cool (**SPXR-A**) or heat pump (**SPXR-HP-A**) models. Having a small footprint (20" X 20") allows the **SPXR-A** to use a minimal amount of floor space. The **SPXR-A** installs easily into a closet having an exterior wall. Like your home, a standard wall mounted thermostat controls the **SPXR-A** unit. Applications for the **SPXR-A** include:

- Hotels / Motels
- High rise apartments / Condominiums
- Assisted Living / Independent care facilities
- Student housing
- Manufactured / Modular buildings

Standard Features: (see pages 4 and 5 for further information)

- Completely pre-charged with environmentally friendly R-410A refrigerant
- Easy access for in-place service of most components
- Multi-function micro-processor board that includes the following functions:
 - Evaporator coil low temperature protection
 - Low ambient lockout
 - Random restart
 - Compressor restart delay
 - Front desk control capability
 - Fan-off delay in the cooling mode
- Service disconnect
- Completely insulated cabinet for sound attenuation and weather infiltration
- Adjustable fresh air damper
- No tool needed to replace the filter
- Weight-supporting, single piece wall sleeves (except side access sleeves) for various wall thicknesses from 5" to 20"
- Sleeves have primary condensate drain connection with secondary overflow to building exterior
- All sleeves are shipped with a weather guard
- Flush type exterior architectural louvers

Optional Features: (see page 8)

- Side access wall sleeves (rear access is standard)
- Custom painted exterior architectural louvers
- Hurricane louver / sleeve combinations
- Various louvered and non-louvered interior access panels
- Digital wall mount thermostats with high and low temperature limits
- **(NEW!) Insulation Kit** - Adds additional 5/8" insulation to three sides of the **SPXR-A** units. (see pages 5 & 8)

SPXR-A Series

Cooling Only

In keeping with its policy of continuous progress and product improvement, First Co. reserves the right to make changes without notice. Maintenance for all First Co. products is available under "Product Maintenance" at www.firstco.com.



	A	B
9,12,18SPXR-A	6-1/2	6-1/2
24SPXR-A	10	3

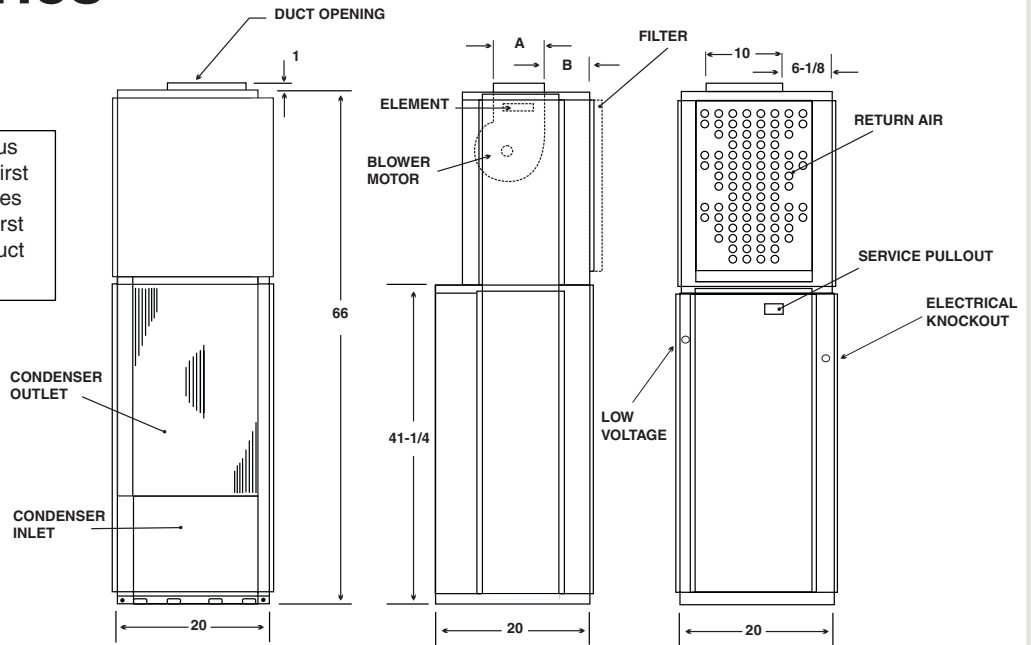

ELECTRICAL DATA (208/230V-1PH-60Hz)																		
UNIT MODEL	ELECTRIC HEAT DATA						BLOWER DATA		CONDENSER DATA				MINIMUM CIRCUIT AMPACITY		MAXIMUM CIRCUIT PROTECTION		SHIP WT.	
	kW		BTUH		TOTAL HEATING AMPS		EVAPORATOR MOTOR		COMPRESSOR		CONDENSER MOTOR		208V	230V	208V	230V		
	230V	208V	230V	208V	230V	208V	AMPS	HP	RLA	LRA	FLA	HP						
9SPXR	-0-A	0	0	0	0	0.0	0.0	.72	1/8	4.4	25	.50	1/15	7	7	15	15	245
	-2-A	2	1.5	6800	5100	9.0	7.9							10	12	15	15	
	-3-A	3	2.25	10200	7700	13.2	11.5							15	17	15	20	
	-4-A	4	3	13600	10200	17.4	15.1							19	22	20	25	
12SPXR	-0-A	0	0	0	0	0.0	0.0	.72	1/8	5.6	29	.72	1/10	9	9	15	15	245
	-2-A	2	1.5	6800	5100	9.0	7.9							10	12	15	15	
	-3-A	3	2.25	10200	7700	13.2	11.5							15	17	15	20	
	-4-A	4	3	13600	10200	17.4	15.1							19	22	20	25	
	-5-A	4.5	3.38	15350	11500	19.5	17.0							22	25	25	25	
18SPXR	-0-A	0	0	0	0	0.0	0.0	.87	1/8	6.5	43	.72	1/10	12	12	20	20	255
	-2-A	2	1.5	6800	5100	9.2	8.1							12	12	20	20	
	-3-A	3	2.25	10200	7700	13.4	11.7							15	17	20	20	
	-4-A	4	3	13600	10200	17.6	15.3							19	22	20	25	
	-5-A	4.5	3.38	15350	11500	19.6	17.1							22	25	25	25	
	-6-A	6	4.5	20500	15350	25.9	22.5							28	33	30	35	
	-8-A	8	6.0	27300	20500	34.2	29.7							37	43	40	45	
	-10-A	9	6.75	30700	23000	38.4	33.3							42	48	45	50	
24SPXR	-0-A	0	0	0	0	0.0	0.0	2.8	1/3	9.9	54	.74	1/8	17	17	20	20	255
	-3-A	3	2.25	10200	7700	15.3	13.6							17	19	20	20	
	-4-A	4	3	13600	10200	19.5	17.3							21	24	25	25	
	-5-A	4.5	3.38	15350	11500	21.6	19.1							24	27	25	30	
	-6-A	6	4.5	20500	15350	27.8	24.5							30	35	30	35	
	-8-A	8	6.0	27300	20500	36.2	31.7							39	45	40	45	
	-10-A	9	6.75	30700	23000	40.3	35.3							44	50	45	50	

BLOWER DATA									
UNIT MODEL	MOTOR SPEED CONN. (1)	CFM vs EXTERNAL STATIC PRESSURE							
		0.05	0.10	0.15	0.20	0.25	0.30	0.35	0.40
9SPXR-A	HIGH	490	480	465	450	440	430	420	410
	MED (H & C)	390	380	370	360	350	340	330	320
	LOW	310	300	290	280	270	260	245	230
12SPXR-A	HIGH	490	480	470	460	450	440	425	410
	MED (H & C)	400	390	380	370	360	350	335	320
	LOW	310	300	290	280	270	260	250	240
18SPXR-A	HIGH	740	730	715	700	685	670	650	630
	MED (C)	670	660	645	630	615	600	585	570
	LOW (H)	560	550	545	530	515	500	485	470
24SPXR-A	HIGH	920	900	880	860	835	810	785	760
	MED (C)	870	860	850	840	820	800	775	750
	LOW (H)	760	750	740	730	720	710	700	690

COOLING / PERFORMANCE DATA		
UNIT MODEL	STANDARD RATING (1)	EER
	BTUH	
9SPXR-A	8900	9.0
12SPXR-A	11500	9.0
18SPXR-A	17400	9.0
24SPXR-A	21500	9.0

(1) Tested at 95°F DB/75°F WB outdoors and 80°F DB/67°F WB indoors.

(2) Tested in accordance with ARI Standard 390.

(1) Factory Settings:
(H) = Heating, (C) = Cooling

SPXR-HP-A Series

Heat Pump

In keeping with its policy of continuous progress and product improvement, First Co. reserves the right to make changes without notice. Maintenance for all First Co. products is available under "Product Maintenance" at www.firstco.com.



	A	B
9,12,18SPXR-A	6-1/2	6-1/2
24SPXR-A	10	3

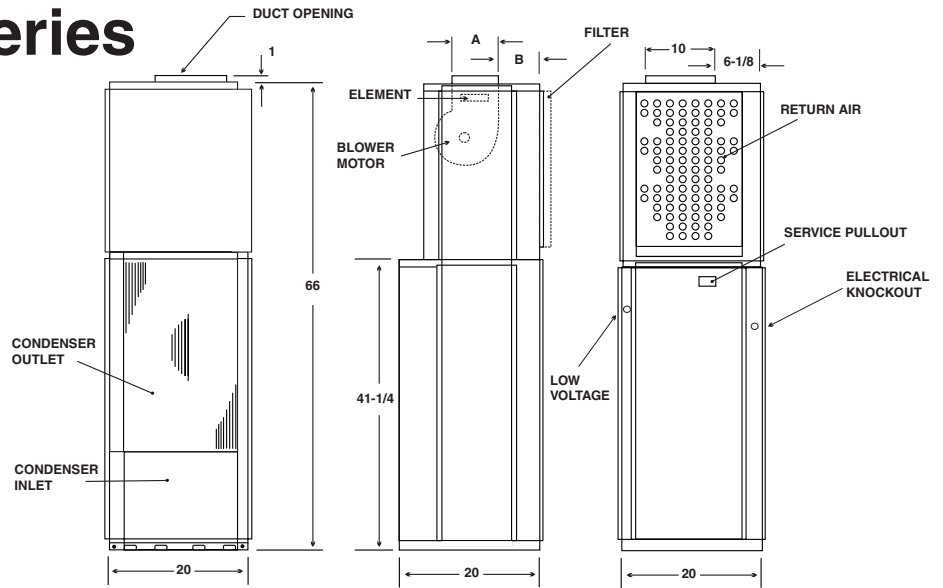

ELECTRICAL DATA (208/230V-1PH-60Hz)

UNIT MODEL	ELECTRIC HEAT DATA						BLOWER DATA		CONDENSER DATA				MINIMUM CIRCUIT AMPACITY		MAXIMUM CIRCUIT PROTECTION		SHIP WT.
	kW		BTUH		TOTAL HEATING AMPS		EVAPORATOR MOTOR		COMPRESSOR		CONDENSER MOTOR						
	230V	208V	230V	208V	230V	208V	AMPS	HP	RLA	LRA	FLA	HP	208V	230V	208V	230V	
9SPXR -2 -3 -HP-A -4	2	1.5	6800	5100	9.0	7.9	.72	1/8	4.4	25	.50	1/15	10	12	15	15	245
	3	2.25	10200	7700	13.2	11.5							15	17	15	20	
	4	3	13600	10200	17.4	15.1							19	22	20	25	
12SPXR -2 -3 -HP-A -4 -5	2	1.5	6800	5100	9.0	7.9	.72	1/8	5.6	29	.72	1/10	10	12	15	15	245
	3	2.25	10200	7700	13.2	11.5							15	17	15	20	
	4	3	13600	10200	17.4	15.1							19	22	20	25	
	4.5	3.38	15350	11500	19.5	17.0							22	25	25	25	
18SPXR -2 -3 -HP-A -4 -5 -6 -8 -10	2	1.5	6800	5100	9.2	8.1	.87	1/8	6.5	43	.72	1/10	12	12	20	20	255
	3	2.25	10200	7700	13.4	11.7							15	17	20	20	
	4	3	13600	10200	17.6	15.3							19	22	20	25	
	4.5	3.38	15350	11500	19.6	17.1							22	25	25	25	
	6	4.5	20500	15350	25.9	22.5							28	33	30	35	
	8	6.0	27300	20500	34.2	29.7							37	43	40	45	
24SPXR -3 -4 -HP-A -5 -6 -8 -10	3	2.25	10200	7700	15.3	13.6	2.8	1/3	9.9	54	.74	1/8	17	19	20	20	255
	4	3	13600	10200	19.5	17.3							21	24	25	25	
	4.5	3.38	15350	11500	21.6	19.1							24	27	25	30	
	6	4.5	20500	15350	27.8	24.5							30	35	30	35	
	8	6.0	27300	20500	36.2	31.7							39	45	40	45	
9	6.75	30700	23000	40.3	35.3	44	50	45	50								

NOTE:

Compressors in these models do not operate simultaneously with heater elements.

BLOWER DATA									
UNIT MODEL	MOTOR SPEED CONN. (1)	CFM vs EXTERNAL STATIC PRESSURE							
		0.05	0.10	0.15	0.20	0.25	0.30	0.35	0.40
9SPXR-HP-A	HIGH	490	480	465	450	440	430	420	410
	MED (H & C)	390	380	370	360	350	340	330	320
	LOW	310	300	290	280	270	260	245	230
12SPXR-HP-A	HIGH	490	480	470	460	450	440	425	410
	MED (H & C)	400	390	380	370	360	350	335	320
	LOW	310	300	290	280	270	260	250	240
18SPXR-HP-A	HIGH	740	730	715	700	685	670	650	630
	MED (C)	670	660	645	630	615	600	585	570
	LOW (H)	560	550	545	530	515	500	485	470
24SPXR-HP-A	HIGH	920	900	880	860	835	810	785	760
	MED (C)	870	860	850	840	820	800	775	750
	LOW(H)	760	750	740	730	720	710	700	690

(1) Factory Settings:
(H) = Heating, (C) = Cooling

COOLING / PERFORMANCE DATA		
UNIT MODEL	STANDARD RATING (1)	EER
	BTUH	
9SPXR-HP-A	8900	9.0
12SPXR-HP-A	11400	9.0
18SPXR-HP-A	17200	9.0
24SPXR-HP-A	21300	9.0

(1) 95°F DB/75°F WB outdoor - 80°F DB/67°F WB indoor.
(2) Tested in accordance with ARI Standard 390.

HEATING / PERFORMANCE DATA (3)		
UNIT MODEL	STANDARD RATING (1)	COP (47°)
	BTUH	
9SPXR-HP-A	8500	3.0
12SPXR-HP-A	11500	3.0
18SPXR-HP-A	16700	3.0
24SPXR-HP-A	20300	3.0

(1) 47°F DB/43°F WB outdoor,
70°F DB/60°F WB indoor.

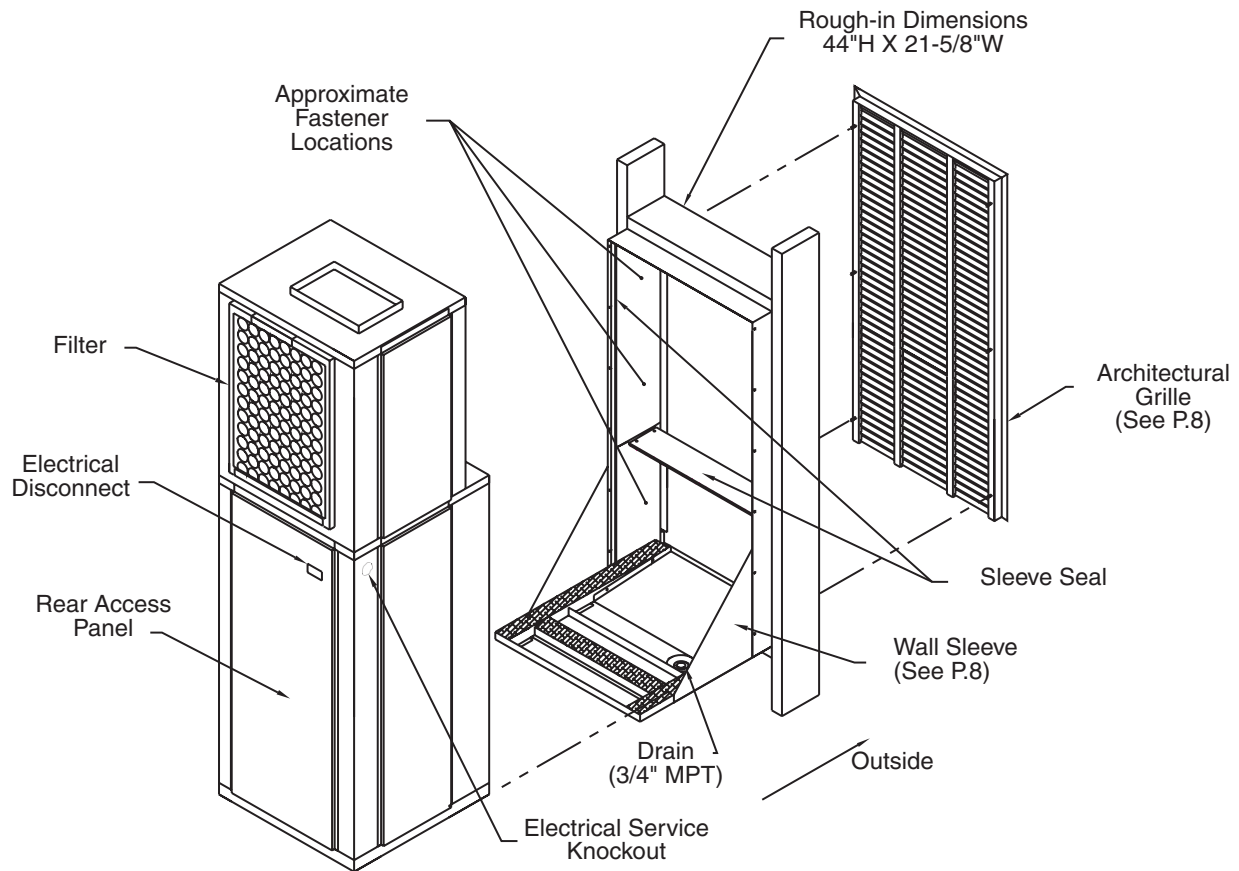

Figure 1 - General Assembly

FEATURES AND BENEFITS

1. **Solid State Circuit Board** - Incorporates the following control features:
 - **Evaporator coil low temperature protection** – During the cooling mode, should the evaporator coil experience either a low temperature condition that could result in ice build up on the coil or a reduced air flow situation, a temperature sensor attached to the coil will de-energize the **SPXR-A** unit. The sensor will re-energize the SPU unit when the coil warms back up.
 - **Low ambient lockout** – Locks out compressor at ambient temperatures below 40°F to extend compressor life.
 - **Random restart** – When power is turned on after a power outage, a built-in random restart (3 to 4 minutes) prevents all compressors from restarting simultaneously.
 - **Compressor restart delay** – This delay ensures that system pressures are allowed to equalize before a compressor restart, which extends compressor life.
 - **Front desk control** – When wired to a front desk console, each unit can then be enabled or disabled from the front desk, thus saving the energy used to condition unoccupied rooms.
 - **Fan delay** – A fan delay allows the evaporator blower to continue running for up to 45 seconds after the thermostat is satisfied. This feature maximizes cooling performance.
2. **Service Pullout** - Factory installed for service convenience and maintenance.
3. **Adjustable fresh air (manual)** - To meet code requirements for fresh air introduction. When opened, the fresh air vent (see Figure 8) allows up to 50 CFM of outside air to be introduced into the equipment closet. The air then mixes with return air entering the closet through the return air grille.
4. **Wall-mounted thermostat** – (See “accessories”, P.8) The **SPXR-A** is easily controlled by a standard low voltage wall thermostat rather than complicated unit-mounted controls. Low voltage wires are “stubbed” out the left side of the cabinet.

FEATURES AND BENEFITS (CONT.)

5. **Wall Sleeve** – (See Figures 1, 4 and 5) Rear or side install wall sleeves are provided for installation during rough-in and, when ready, the **SPXR-A** unit is simply slid into the sleeve and the ductwork and electrical connected. The sleeve is a weight-bearing sleeve that supports the entire weight of the **SPXR-A** unit and provides a weather tight seal against wind and water infiltration. A 3/4" male NPT fitting is provided in the bottom of the sleeve for field connection to a condensate riser. Four wall sleeve depths are available to accommodate wall thickness from 5" to 20". Each sleeve includes a factory installed "weather guard" to cover the sleeve opening during construction.

6. **Unique "Sleeve Drain" Condensate System** - (Also see Figure 4) A factory installed drain line connects the evaporator drain pan to a vertical pipe connection in the **SPXR-A** base pan. Evaporator condensate is delivered from the **SPXR-A** unit to a

catch tray in the wall sleeve and exits the sleeve through the 3/4" male NPT fitting. This design allows the plumber to completely pipe the drain to a condensate riser during the rough-in stage, thus eliminating condensate connection problems usually encountered when trying to connect the HVAC drain to the riser after the HVAC unit is installed in the closet. This features also allows the **SPXR-A** unit to be removed for

"Rear Install" sleeve shown

service without disconnecting the condensate piping! This configuration does not require any additional closet space to make the drain connection, as do some competitive products.

7. **Secondary overflow:** If for any reason the primary condensate riser becomes clogged, water will fill the catch tray and then be diverted through the sleeve to the exterior of the building, rather than be allowed to overflow into the closet or living area. Rain water entering the sleeve is automatically diverted to the building exterior as well.

8. **Ductable return air** – Return air can be ducted to the unit. However, most installations would not normally require ducted return air.

9. **New "Flush Style" Architectural Louver** – (See Figure 6) This new louver is an attractive extruded aluminum architectural louver that attaches to the outside face of the wall sleeve. The blades of this unique grille **recess** into the wall sleeve for a neat, "flush" appearance. Louvers install from the inside of the wall sleeve. Do not install the **SPXR-A** unit into the sleeve before installing the louver.

10. **Filter Brackets** – (See Figure 7) Filter Brackets and throw away filter are shipped with each unit and are field installed over the unit's evaporator coil. Filter size is 18 x 24 x 1.

11. **Insulation kit** (#91k01) - The interior of all **SPXR-A's** is lined with 1/2" fiberglass as standard. The 91K01 kit is designed to be used in any application where additional insulation is desired. The kit includes three sections of 5/8" foil faced ductboard insulation that are screwed together in the field and cover the three sides on the condenser section.

Figure 2



SHOWN WITH OPTIONAL LOUVERED ACCESS PANEL (See P.8)

NOTE: A solid door or panel in front with a side wall return air grill will result in lower sound levels.

Figure 3

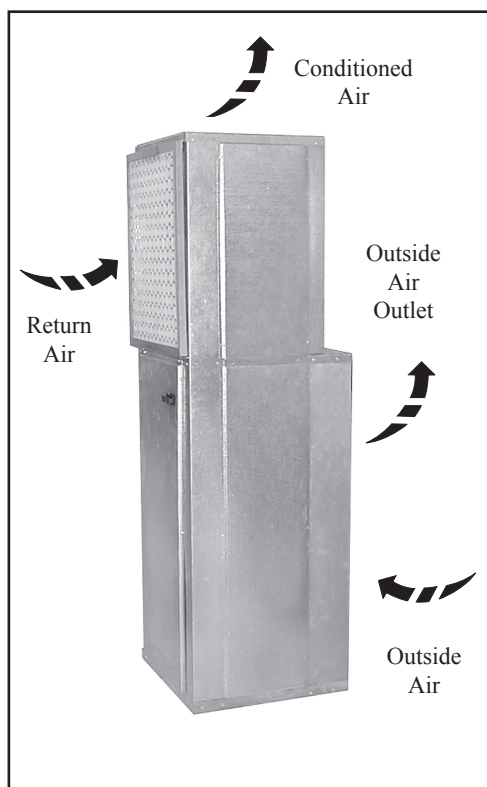

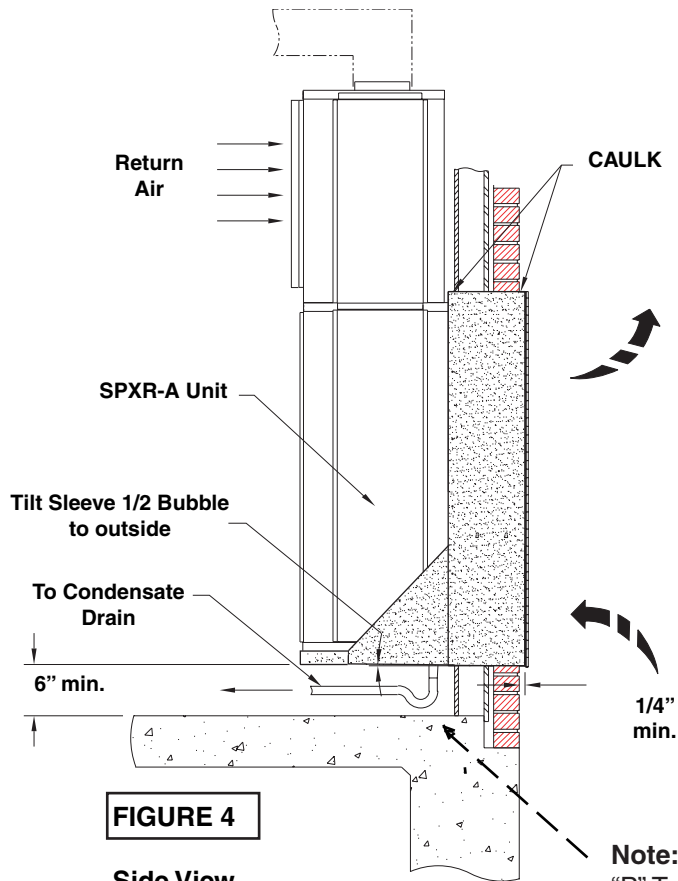

FIGURE 4

**Side View
(with "Rear Install" sleeve)**

Note:
"P" Trap is shown for illustration purposes only - It may not be required by local codes.



FIGURE 5

Side Install Sleeve

Note:
Separate wall mounting bracket is shipped with "side install" wall sleeves.

UNIT / SLEEVE DIMENSIONS					
Part Number		Fits Wall Thickness	A	B	C
Rear Install	Side Install				
936-1B	936-11B	5" - 8" wall	9"	17"	26"
936-2B	936-12B	8" - 12" wall	13"	17"	30"
936-3B	936-13B	12" - 15" wall	16"	17"	33"
936-4B	936-14B	15" - 20" wall	21"	17"	38"



FIGURE 6

(Unit shown with "Rear Install" sleeve)

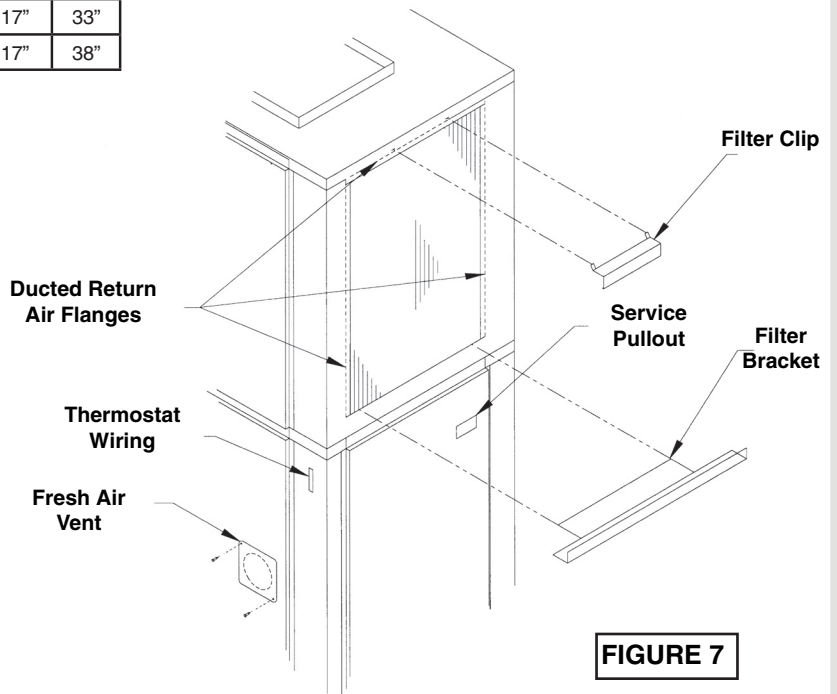

FIGURE 7

Filter Bracket Detail

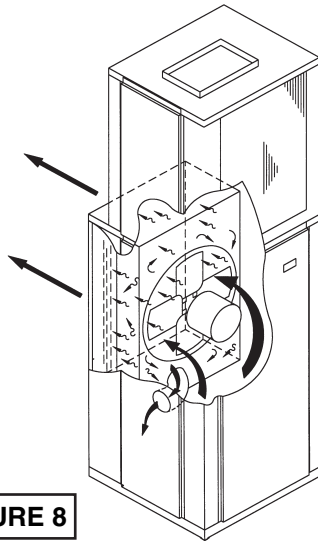
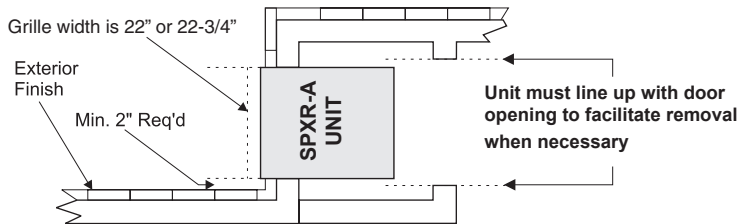

FIGURE 8

One end of a 3" aluminum vent pipe is connected to the condenser venturi and the other end is connected to the side of the **SPXR-A** cabinet. A mesh screen is installed inside the vent pipe and a metal plate on the side of the cabinet covers the opening of the vent pipe. Up to 50 CFM of fresh air is introduced into the equipment closet by removing the metal cover plate. The fresh air then mixes with the return air and is then pulled through the evaporator coil and into the supply duct. The cover plate can be re-installed to partially close the fresh air opening if less than 50 CFM is desired. An external source of negative pressure (i.e. a bathroom fan) could be used to introduce more than 50 CFM of fresh air. Consult with factory for further details.

SPXR-A Rear Installation Detail



Notes:

1. Sleeve rough-in opening is 44"(H) X 21-5/8"(W).
2. Bottom of opening should be approx. 6" above floor level.
3. Minimum 3" of clearance is required on all sides of the **SPXR-A** unit.

SPXR-A Closet Dimensions - Rear Installation

Instructions:

To find the minimum closet depth (dimension "C"), use the following method:

Determine dimension "A" which is the total finished wall thickness.

- For 5"-8" outside wall thickness, subtract "A" from 29".
("C" = 29 - "A")
- For 8"-12" outside wall thickness, subtract "A" from 33".
("C" = 33 - "A")
- For 12"-15" outside wall thickness, subtract "A" from 36".
("C" = 36 - "A")

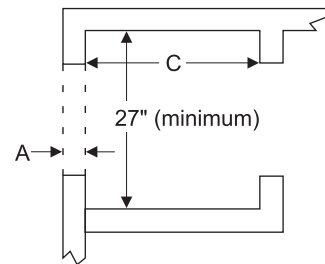

SPXR-A Closet Dimensions - Side Installation

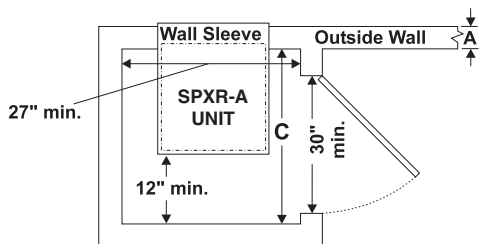

Instructions:



To find the minimum closet depth (dimension "C"), use the following method:

Determine dimension "A" which is the total finished wall thickness.

- For 5"-8" outside wall thickness, subtract "A" from 39".
("C" = 39 - "A")
- For 8"-12" outside wall thickness, subtract "A" from 43".
("C" = 43 - "A")
- For 12"-15" outside wall thickness, subtract "A" from 46".
("C" = 46 - "A")

Notes:

1. Sleeve rough-in opening is 44"(H) X 21-5/8"(W).
2. Bottom of opening should be approx. 6" above floor level.
3. Minimum 3" of clearance is required on the sides of the **SPXR-A** unit and 12" clearance on the rear of the unit .

ACCESSORIES (sleeves, louver, and thermostat required for each installation)							
ACCESSORY	DESCRIPTION	DIMENSIONS (HXWXD)	PART NUMBERS			SHIP WT. (EA)	
			STANDARD SLEEVES		HURRICANE (5)		
			REAR INSTALL (non-Hurricane)	SIDE INSTALL (3) (non-Hurricane)	REAR INSTALL (side install n/a)	REAR	SIDE
WALL SLEEVES (2)	For 5" - 8" thick walls	43-3/4 x 21-3/8 x 26	936-1B	936-11B	936-1H	59 (4)	64 (4)
	For 8" - 12" thick walls	43-3/4 x 21-3/8 x 30	936-2B	936-12B	936-2H	63 (4)	68 (4)
	For 12" - 15" thick walls	43-3/4 x 21-3/8 x 33	936-3B	936-13B	936-3H	68 (4)	73 (4)
	For 15" - 20" thick walls	43-3/4 x 21-3/8 x 38	936-4B	936-14B	936-4H	75 (4)	80 (4)
ARCHITECTURAL LOUVERS	Standard	44 x 22	G205S (1)	G205P	G205A	12	
	Hurricane	45-5/8 x 22-3/4	G215S (1)	G215P	G215A	22	
THERMOSTATS	Straight Cool (24V) Digital cool - off - heat, auto - on w/limits-(6-wire)	4 x 5 (Horizontal)	T630NC			---	
	Heat Pump (24V) Digital w/emergency heat cool - off - heat, auto - on w/limits-(6-wire)	4 x 5 (Horizontal)	T621-HPNC			---	
	Programmable (5-2) st. Cool/Ht. Pump (24V) cool-off-heat, auto-on w/em. Ht. & limits (6-wire)	4 x 5 (Horizontal)	T62200NC			---	

NOTES:

- (1) "S" indicates custom color, to be provided by customer. Minimum order quantity is 20 per color.
- (2) Rear install application provides better access to the **SPXR-A** unit and is recommended over "side install" wherever possible.
- (3) Side install application requires different closet size and configuration. (See P.7) Contact factory for further information.
- (4) All wall sleeves are shipped two (2) per carton.
- (5) Hurricane sleeves require special louver (see "Architectural Louvers" above)
(contact the factory for information about hurricane sleeves and louvers)

OPTIONAL ACCESSORIES (field installed)					
COMPONENT	DESCRIPTION	DIMENSIONS (H X W)		PART NUMBER	SHIP WT.
		FRAME	OPENING		
ACCESS / RETURN AIR PANEL (3)(4)	LOUVERED (1)	87 X 31	84 X 28	931-11	55
	NON-LOUVERED (2)	87 X 31	84 X 28	931-12	
	LOUVERED (1)	82 X 31	79 X 28	931-13	55
	NON-LOUVERED (2)	82 X 31	79 X 28	931-14	
INSULATION KIT	3/8" DUCT BOARD	N/A		91K01	---

NOTES:

- (1) Includes 18 x 24 x 1 filter.
- (2) Requires external return air grille and unit mount filter.
- (3) Both panels are insulated for sound reduction and have tamperproof screws.
- (4) Panels are shipped ten per carton.



(91K01)

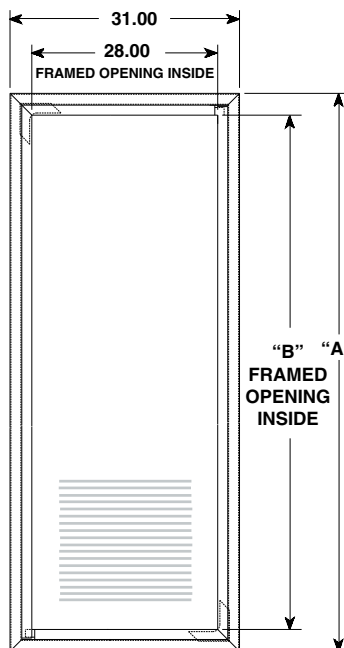

NOTE: A solid door or panel with a side wall return air grille will result in lower sound levels.

MODEL NUMBER NOMENCLATURE

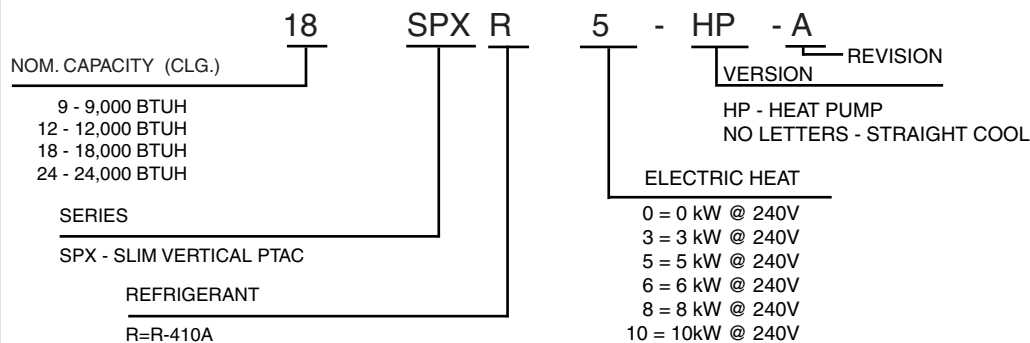

PART NO.	"A"	"B"
931-11	87.00	84.00
931-13	82.00	79.00