

WITH ECM MOTOR!!



NEW MODELS  
ADDED (20, 26, 32)

## UCX Series

Wall, Closet Air Handler  
1.5 - 3.0 Tons Cooling or Heat Pump  
Up to 10 kW Electric Heat



Unit shown with louvered wall panel  
(Recessed wall application)



Unit shown without wall panel  
(Closet application - Front Return Air)



Unit shown with bottom return air cover  
(Closet application - Bottom Return Air)

These upflow air handlers are designed for use with today's higher efficiency split-system condensing units and heat pumps. All **UCX** fan coils include an ECM motor. These motors offer the efficiency of a variable speed type ECM motor, but at a considerably lower cost.

(1) **First Co's customer is ultimately responsible for confirming which fan coil models are compatible with selected outdoor unit(s) and which expansion valves (if any) are required. To determine approved indoor/outdoor matches, go to: [www.firstco.com](http://www.firstco.com) or contact the factory.**

The **UCX** can be installed on a closet platform, hung on a closet wall, or recessed in a wall between the studs. All models are 22" wide to allow standard stud spacing for all sizes.

The cabinet is made of galvanized steel and is fully insulated. The non-corrosive thermoplastic condensate pan is sloped to ensure proper drainage. For installation flexibility, drain piping can come from the bottom, front, left, or right side of the cabinet.

**New Feature:** - The removable door of the optional wall panel now includes "captive screws" that won't fall out when the door is removed for service or filter change.

### Standard Features:

- **High efficiency ECM motor**
- Factory installed disconnect
- 240V motor, 24V controls
- Factory or field installed R-410A TXV (cooling or heat pump operation).
- Non-corrosive thermoplastic drain pan, sloped for positive drainage with 3/4" MPT primary and secondary connections
- Separate compartment for drain connections allows the field use of PVC drain piping
- Easily accessible 1" throwaway filter

### Optional Features: (see Page 4)

- Optional features include wall panels with captive screws, condensate overflow switch, closet hanger bracket kit, and bottom return air kit.

### Optional Features: (see Page 4)

Optional accessories include Field Installed Heater Kits (only for 0kW models) , Factory or Field Installed TXV Kits, Wall Panels with Captive Screws, Condensate Overflow Switch, Closet Hanger Bracket Kit, and Bottom Return Air Kit

# UCX Series

## Wall / Closet Fan Coils

(See P. 3 for Model Numbers)

PERFORMANCE DATA													
UNIT MODEL		NOM. CFM	NOM. COOL BTUH	ELECTRIC HEAT CAPACITY				TOTAL AMPS		MIN. AMPACITY		MAX. OVERCURRENT PROTECTION	
				kW		BTUH		240V	208V	240V	208V	240V	208V
				240V	208V	240V	208V						
19UCX 20UCX	0-HK	600	18000	0	0	0	0	2.80	2.80	4	4	15	15
	2			1.5	6824	5118	11.13	10.01	14	13	15	15	
	3			2.3	10236	6824	15.30	13.61	20	18	20	20	
25UCX 26UCX	4	800	24000/ 18000	4	3.0	13648	10236	19.47	17.22	25	22	25	25
	5			3.8	17061	13648	23.63	20.83	30	27	30	30	
	6			4.5	20473	15355	27.80	24.43	35	31	35	30	
	8			6.0	27297	20473	36.13	31.65	46	40	50	40	
	10			7.5	34121	25591	44.47	38.86	56	49	60	50	
31UCX 32UCX	0-HK	1000	30000/ 24000	0	0	0	0	4.10	4.10	6	6	15	15
	2			1.5	6824	5118	12.43	11.31	16	15	20	15	
	3			2.3	10236	6824	16.60	14.92	21	19	25	20	
	4			3.0	13648	10236	20.77	18.52	26	24	30	25	
	5			3.8	17061	13648	24.93	22.13	32	28	35	30	
	6			4.5	20473	15355	29.10	25.73	37	33	40	35	
	8			6.0	27297	20473	37.43	32.95	47	42	50	45	
10	7.5	34121	25591	45.77	40.16	58	50	60	50				
37UCX	0-HK	1200	36000/ 30000	0	0	0	0	6.00	6.00	8	8	15	15
	2			1.5	6824	5118	14.33	13.21	18	17	20	20	
	3			2.3	10236	6824	18.350	16.82	24	22	25	25	
	4			3.0	13648	10236	22.67	20.42	29	26	30	30	
	5			3.8	17061	13648	26.83	24.03	34	31	35	35	
	6			4.5	20473	15355	31.00	27.63	39	35	40	35	
	8			6.0	27297	20473	39.33	34.86	50	44	50	45	
10	7.5	34121	25591	47.67	42.06	60	53	60	60				



In keeping with its policy of continuous progress and product improvement, First Co. reserves the right to make changes without notice. Maintenance for all First Co. products is available under "Product Maintenance" at [www.firstco.com](http://www.firstco.com).

**NOTES:**

- (1) 0 - 10 kW is available for ALL UCX models

PERFORMANCE DATA							
UNIT MODEL	MOTOR HP	FAN SPEED TAP	CFM VS. EXTERNAL STATIC PRESSURE				
			0.10	0.20	0.30	0.40	0.50
19UCX 20UCX	1/3	5	780	760	730	690	650
		4	620	590	560	530	500
		3	560	520	480	450	420
25UCX 26UCX	1/3	5	850	810	770	730	690
		4	780	750	720	690	660
		3	680	640	610	580	550
		2	600	570	540	500	460
31UCX	1/2	4	940	900	860	820	780
		3	930	890	820	810	770
		2	810	790	770	750	730
		1	710	690	670	650	630
32UCX	3/4	4	1180	1140	1100	1050	990
		3	1090	1060	1030	1000	960
		2	860	830	800	770	740
		1	720	680	640	600	560
37UCX	3/4	5	1330	1270	1210	1150	1090
		4	1180	1150	1120	1090	1050
		3	1040	1010	990	950	910
		2	930	910	880	850	820

**NOTES:**

- 1. Shaded rows are factory preset speeds.
- 2. Cooling = High Speed, Heating = Low Speed
- 3. Contact factory for correct matches with outdoor units.
- 4. Approved for installation with "0" clearance to combustible material.

PHYSICAL DATA									
UNIT MODEL	A	B	C	D	E	F	FILTER SIZE	LIQUID LINE	SUCTION LINE
19-25UCX	22-1/8	15-1/8	40	14	10-1/2	3-5/8	18 X 18	3/8 O.D.	5/8 O.D.
26, 31UCX	22-1/8	15-1/8	40	14	10-1/2	3-5/8	18 X 20	3/8 O.D.	3/4 O.D.
32, 37UCX	22-1/8	18-1/8	43	14	13	3-5/8	18 X 24	3/8 O.D.	3/4 O.D.

**NOTES:**

- 1. Coil connections are sweat

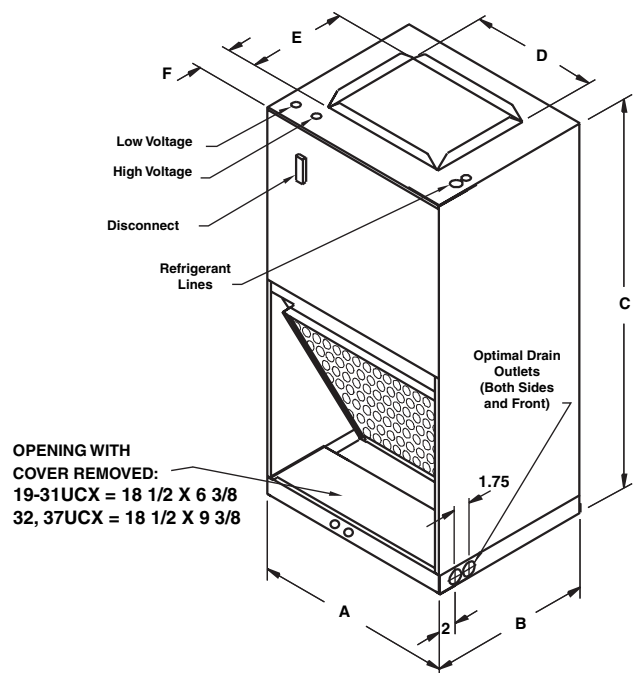

# UCX Series

## Wall / Closet Fan Coils

### MODEL NUMBERS:

MODEL SIZE (BTU)	MODEL (PISTON)	MODEL (R410A TXV)
18,000	19UCX(_)	19UCX(_) R410 TXV
18,000	20UCX(_)	20UCX(_) R410 TXV
24,000 / 18,000	25UCX(_)	25UCX(_) R410 TXV
24,000 / 18,000	26UCX(_)	26UCX(_) R410 TXV
30,000 / 24,000	31UCX(_)	31UCX(_) R410 TXV
30,000 / 24,000	32UCX(_)	32UCX(_) R410 TXV
36,000 / 30,000	37UCX(_)	37UCX(_) R410 TXV

**All models are approved for cooling only or heat pump operation.**

(\_) = kW HEAT (0-HK = NO HEAT)

**NOTE:**

- Expansion valve requirement depends on the selected outdoor unit.  
Go to: [www.firstco.com](http://www.firstco.com) or contact the factory for assistance.
- For field installed TXV order "Piston" model and TXV kit #9EVR410-1 (see P.4)

**(See P. 4 for Optional Accessories)**

# UCX Series

## Wall / Closet Fan Coils

OPTIONAL ACCESSORIES (FIELD INSTALLED)				
DESCRIPTION	PART #		DIMENSIONS	
	19 - 31UCX	32, 37UCX	OUTSIDE FRAME	INSIDE FRAME
WALL PANEL (1)	9PWUC01L	---	25-5/8 X 43-3/8	22-5/8 X 40-3/8
WALL PANEL (1)	---	9PWUC02L	25-5/8 X 46-3/8	22-5/8 X 43-3/8
HANGER BRKT. SET	90PK3	90PK3	1-1/2 X 22-1/8	---
RETURN AIR COVER	90PK4	---	19-13/16 X 22	---
RETURN AIR COVER	---	90PK5	21-5/8 X 22	---
3kW HEATER KIT (2)	9EHUC1-203 (2)	9EHUC2-203 (2)	---	---
5kW HEATER KIT (2)	9EHUC1-205 (2)	9EHUC2-205 (2)	---	---
6kW HEATER KIT (2)	9EHUC1-206 (2)	9EHUC2-206 (2)	---	---
8kW HEATER KIT (2)	9EHUC1-208 (2)	9EHUC2-208 (2)	---	---
10kW HEATER KIT (2)	9EHUC1-210 (2)	9EHUC2-210 (2)	---	---
CONDENSATE OVERFLOW SWITCH	SS3	SS3	---	---



Optional wall panel  
(Recessed wall application)

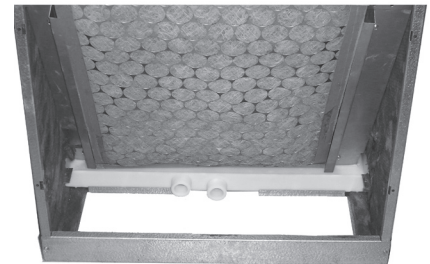

Condensate drain connections  
(With drain access cover removed)  
(Male connections shown)



Condensate Overflow Switch  
#SS3

EXPANSION VALVE KITS (Heat Pump or cooling only) (FIELD INSTALLED)		
PART NO.	TYPE	FOR
9EVR410-1	R410A	19 - 37UCX (1-1/2 - 3 TON)

**NOTES:**

- Above expansion valve kits are approved for both cooling only (non heat pump) or heat pump applications.
- Valves are external equalizing, internal bleed.
- Valves mount inside unit cabinet.



Unit shown with optional  
bottom return air kit  
(#90PK4 or #90PK5)